



CIRCULATING AIR SOURCE HEAT PUMP WATER HEATER SERVICE MANUAL

T1/R410A/50Hz
(GC201510 – II)

Contents

CHAPTER I PRODUCT INTRODUCTION.....	1
1. INTRODUCTION OF UNIT	1
2. BASIC WORKING PRINCIPAL	2
3. BASIC PARAMETERS OF UNIT	4
4. OPTIONAL FITTINGS	5
CHAPTER II INSTALLATION	6
1. INSTALLATION FLOW CHART.....	6
2. PREPARATION BEFORE INSTALLATION.....	6
3. INSTALLATION FOR MAIN UNIT OF WATER HEATER.....	10
4. DESIGN OF WATER SYSTEM.....	13
5. INSTALLATION AND HEAT INSULATION FOR PIPELINES OF WATER SYSTEM.....	19
6. ELECTRIC INSTALLATION	34
7. INSTALLATION OF COMMUNICATION SYSTEM.....	41
8. CHARGING OF REFRIGERANT	43
CHAPTER III DEBUGGING AND OPERATION	46
1. DEBUGGING FLOW CHART	46
2. SAFETY NOTICES	46
3. PRE-DEBUGGING PREPARATIONS	47
4. DEBUGGING OPERATION	50
5. UNIT FUNCTION SETTINGS	53
CHAPTER IV MAINTENANCE.....	56
1. ERROR CODE	56
2. TROUBLESHOOTING	59
3. MAINTENANCE OF KEY PARTS	66
4. UNIT EXPLOSION VIEW AND PARTS LIST	90
CHAPTER V UNIT MAINTENANCE.....	102
1. DAILY OPERATION AND MAINTENANCE	102
2. CLEANING OF SYSTEM	102

Chapter I Product Introduction

1. Introduction of Unit

1.1 Product Overview



GRS-Cm28/NaA-M、GRS-Cm28/NaA1-M
GRS-Cm36/NaA-M、GRS-Cm36/NaA1-M



GRS-Cm53/NaA-M、GRS-Cm53/NaA1-M

1.2 Operating Range of Unit

Product operation range	
Item	Outdoor ambient temperature
Operation range for generating hot water	-26~46℃

2. Basic Working Principal

2.1 Introduction of Working Principal

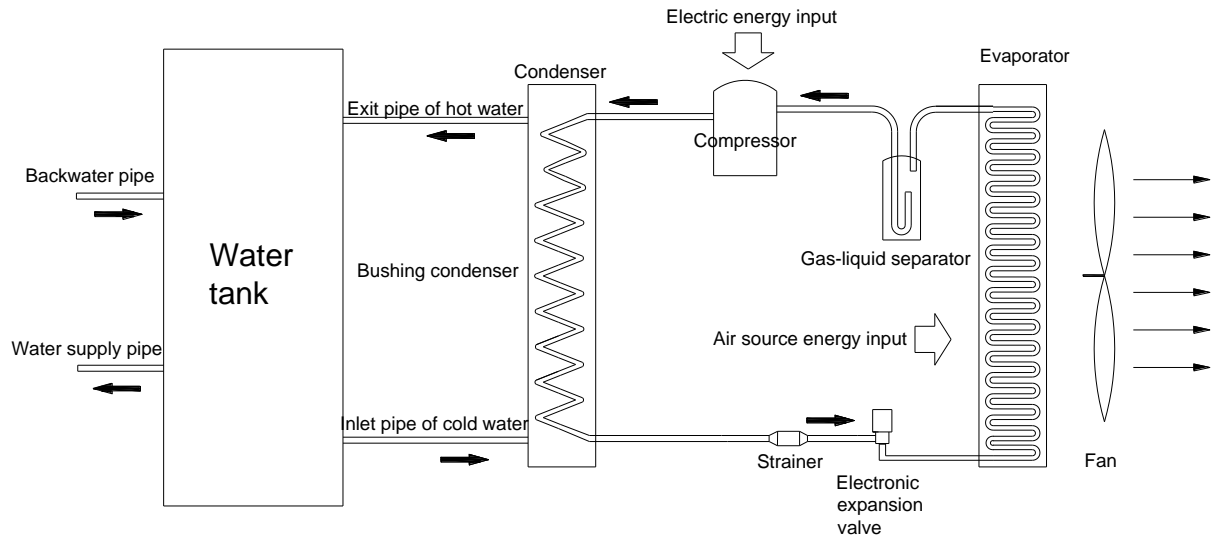

The water heater starts to work after being energized, and then enters into heating. After the low-temperature and low-pressure refrigerant gas is absorbed by compressor, it will be compressed to be high-temperature and high-pressure gas, and then it enters into heat exchanger of water side to conduct heat exchange with water, through which the refrigerant becomes liquid, and then the liquid refrigerant enters into the heat exchanger of air side via depressurization and cooling of electronic expanding valve, it will conduct heat exchange with the ambient air inside the heat exchanger of air side; after being evaporated to be low-temperature and low-pressure refrigerant gas, it will return to the compressor and enter into the next cycle. At the same time, the water inside the heat exchanger of water side which for conducting heat exchange with refrigerant is heated and will flow to thermal insulating water tank by the driving of water pump.

2.2 Name and Main Function of Different Parts

No.	Name	Main Function
1	Compressor	Acting as the heat of water heater system, compress the refrigerant to be high-temperature and high-pressure gas, promote the flowing of refrigerant inside the system.
2	Oil temperature heating belt of compressor	Under stand-by status, keep the oil temperature of compressor; ensure the reliability for restarting the unit.
3	Pressure switch	When the pressure of refrigerant exceeds the operate value of pressure switch, it will feed back to stop the operation of unit, so as to protect the compressor.
4	4-way valve	It is used for the transformation between heating and defrosting of system.
5	Heat exchanger of evaporator	When the refrigerant enters into evaporator and conducts heat exchange with air, the heat exchanger of evaporator will absorb the energy from air for the unit.
6	Fan	Enhance the heat exchange of evaporator.
7	Defrosting temperature sensor	For defrosting inspection.
8	Electronic expanding valve	On the one hand is for throttle and depressurization of high-pressure liquid refrigerant, ensuring the pressure difference between condenser and evaporator; on the other hand is for adjusting the flow volume of refrigerant entering into evaporator, so as to adapt to the variation of heat load of evaporator and ensure steady operation of cooling device.
9	Gas-liquid separator	For separating gas and liquid to prevent the compressor from being operated under humid environment.
10	Double pipe condenser	The high-temperature and high-pressure gas discharged from compressor will release heat inside the double pipe heat exchanger to heat the water.

3. Basic Parameters of Unit

Model			GRS-Cm28/NaA-M GRS-Cm28/NaA1-M	GRS-Cm36/NaA-M GRS-Cm36/NaA1-M	GRS-Cm53/NaA-M GRS-Cm53/NaA1-M
Product Code			ER01000150 ER01000180	ER01000160 ER01000190	ER01000170 ER01000200
Hot water mode	Heating capacity	kW	28	36	53
	Heating Power Input	kW	7.3	9.3	13
	Heating Current Input	A	13.9	16.9	26
	Nominal Water Output	L/h	602	775	1140
Rated Input		kW	10.1	13.2	19
Rated current Input		A	20	24	38
Set temperature		°C	defaulted at 50°C. 30°C~60°C adjustable (water tank temperature)		
Power			380-415V 3N~50Hz		
Refrigerant	Name		R410A	R410A	R410A
	Refrigerant charge volume	kg	4.2	4.2	5.9
Compressor	Type		Totally-enclosed scroll compressor		
	Q'ty	Set	1	1	1
Heat exchanger	Wind side		Finned type heat exchanger		
	Water side		Shell-and-tube heat exchanger		
Fan	Type		Low noise axial flow fan		
	Air discharge type		Top air discharge		
	Airflow(ambient temperature 25°C)	m ³ /h	11400	11400	12400
Water system	Circulating Water Flow	m ³ /h	4.8	6.2	9.2
	Water pressure	kPa	70	130	70
	Maximum bearing pressure	MPa	0.8	0.8	0.8
	Diameter of air inlet pipe and air outlet pipe	in	G 1-1/4	G 1-1/4	G 2
Outline dimension	WxDxH	mm	930x800x1605	930x800x1605	1340x800x1605
Packing size	WxDxH	mm	1010x865x1775	1010x865x1775	1420x880x1775
Noise		dB(A)	≤67	≤67	≤67
Unit net weight		kg	243、242	260、262	358、364

①Data in the above table are based on the following test conditions: outdoor ambient temperature: 20°C DB/15°C WB; initial water temperature: 15°C; final water temperature:55°C; Voltage: 380V 3N~50Hz.

②Applicable range: ambient temperature range is -26°C~46°C.

③The above pressure values all belong to gauge pressure.

④Noise is tested in the semi-silencing room. The actual noise will be a little higher in the actual operation environment.

⑤Circulating water flow means the rated flow during the heating operation. When selecting the water pump model, it shall refer to the flow after overcoming the water resistance, that is, the flow of corresponding delivery lift, rather than the maximum flow labeled in the nameplate of water pump.

⑥The listed water resistance refers to the water resistance under rated working conditions. If the ambient temperature and water inlet temperature are different, unit's hot water output will be changed accordingly, and the water resistance may be different from the listed value.

⑦If the specification is changed due to the product improvement, please refer to the nameplate.

⑧The system reliability and the different water temperature requirement under different water temperature are considered for this product and limit the maximum water tank temperature for stop operation.

The curve is as below:

Curve of maximum water tank temperature for stop operation with the change of ambient temperature					
Ambient temperature/°C	Tank temperature/°C	Ambient temperature/°C	Tank temperature/°C	Ambient temperature/°C	Tank temperature/°C
-26	53	-1	58	24	60
-25	53	0	58	25	60
-24	53	1	58	26	59
-23	53	2	58	27	59
-22	53	3	59	28	58
-21	54	4	59	29	58
-20	54	5	59	30	58
-19	54	6	59	31	57
-18	54	7	60	32	57
-17	54	8	60	33	57
-16	55	9	60	34	56
-15	55	10	60	35	56
-14	55	11	60	36	56
-13	55	12	60	37	55
-12	55	13	60	38	55
-11	56	14	60	39	55
-10	56	15	60	40	54
-9	56	16	60	41	54
-8	56	17	60	42	54
-7	57	18	60	43	53
-6	57	19	60	44	53
-5	57	20	60	45	53
-4	57	21	60	46	52
-3	57	22	60		
-2	58	23	60		

4. Optional Fittings

Circulating air source heat pump water heater includes the following optional fittings:

Supplying Contents	Model	Remarks
Packaged Attachment	CF122	The packaged attachment contains operating instruction manual、liquid level switch、display board Z26301K、sensor sub-assy and so on.

Chapter II Installation

1.Installation Flow Chart

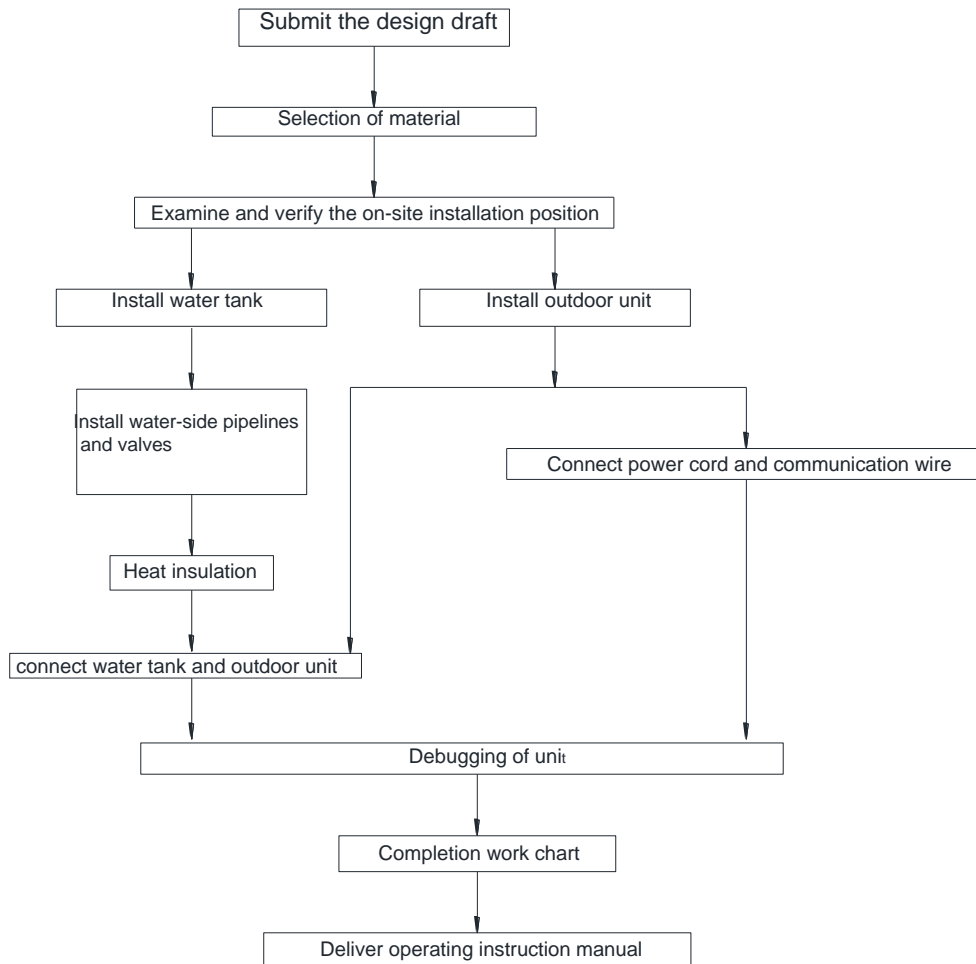

2. Preparation Before Installation

2.1 Matters Need Attention During Installation

2.1.1 Safety requirements for installation and construction



Warning! Before construction, all the constructors must have had the safety education and have passed the safety examination. Once there is violating behavior, the constructor should bear related liabilities.



Warning! During the installation and construction, personal and property safety must be placed in the first place. During the construction, constructors must abide by the national related safety criterion to avoid personal injury or property loss.

2.1.2 Importance of installation

Water heater adopts direct evaporative type cooling system, which has high requirement for the cleanliness and dryness of inner pipelines of the system. When manufacturing and laying pipelines in the construction site,

No.	Installation Problem	Existing Influence
1	Incorrect connection of PPR pipeline and then leads to blockage	The unit enters into protection mode and does not yield hot water; or the water flow is too small to satisfy the using demand.
2	Cooling water inlet pipe has not been installed with filter and then leads to blockage	
3	The installation position of outdoor unit is in bad ventilation condition	When the ambient temperature is high, the unit is likely to arise high-pressure protection and then close down.
4	The outdoor unit has not been fixed	There will be large noise during the operation of unit
5	Bad heat insulating condition of pipelines or there is no heat insulation for pipelines	There will be great loss of heat, the water temperature cannot satisfy the using demand.
6	Water pressure of tap water is not great enough, or water pressure of tap water is too high that there is no corresponding remedial measure	The unit cannot operate normally, which may cause complaint of client.
7	Improper protection of control communication wire	The communication wire appears short circuit or open circuit, the unit has communication error and cannot be started up.
8	Has not well communicated with user and has not installed return pipe.	The hot water cannot yield until long time of discharging cooling water

2.1.3 Professional coordination

The installation of product can hardly do without the coordination with the construction, structure, electric, water supply and drainage, fire control, decoration and related conditions. Layout of pipeline should keep away from the fire control automatic spray header, and the pipelines should be properly arranged according to the layout of electric, lighting, and decoration.

- 1) Reserve holes and sleeving;
- 2) Reserve installing space for main unit and water tank, prepare the basis; installation position of main unit should satisfy the requirements for bearing, ventilation and maintenance of

unit;

3) If there are no reserving holes, the holes can be drilled, but it is not allowed to drill on the spandrel girder or load bearing wall.

4) Pipelines for cooling water, hot water and return pipe should be prearranged, and should reserve interfaces for the pipelines of cooling water, hot water and return pipe;

5) The indoor hot water pipelines should be kept in good heat insulation.

6) Reserve special route for water heater, type of power source and electric capacity should satisfy the using requirements;

7) Check if the power cord and air switch satisfy the requirement of unit, whether they comply with local safety criterion and law;

8) Check if the regional power supply quality (including voltage pulsation and interference wave) can satisfy the requirements of local safety criterion and law; if not, please coordinate and solve the problem.

2.2 On-site Examination and Verification of Design Draft

Installation personnel should carefully read the designing plan and draft provided by designer, and conduct verification and examination according to on-site conditions, and propose reasonable revised suggestion in time.

Confirmation sheet of construction design draft for examination and verification:

No.	Contents for Confirmation	Result
1	Check if the installation position of unit has satisfied the space requirement for heat exchanger and maintenance	
2	Check if the pipe diameter of water pipe has satisfied the operating requirement of unit	
3	Check if there is return pipe	
4	Check if there is auxiliary electric heating equipment	
5	Check if the power cord specification and type can satisfy the designing requirement of unit	
6	Check if the manufacture, total length and control mode of control wire can satisfy the designing requirement of unit	
7	Check if the design of reserving interface for water tank can satisfy the connection and control requirements of unit	



Notes: The installation personnel must conduct strictly abide by the design draft. During the installation, if the actual installing situation cannot satisfy the designing requirement,

installation personnel should seek confirmation from the designer and make a Design Alteration Record in written form.

2.3 Selection of Installation Materials

2.3.1 Notices for Selecting Installation Materials

1) If the brand and dimension of installation materials are designated, users should purchase the materials according to the requirements; if there are no designated installation materials, the materials purchased by users must be in accordance with the local criterion and quality requirement.

2) The materials, equipments and appliances for installation should have certificate of qualification or inspection report;

3) Products with fire control requirement should have fire control inspection certificate and should comply with local and related compulsory standards;

4) If it is required to use eco-friendly materials, all the materials must comply with the local eco-friendly requirements and should provide related certificates.

2.3.2 Requirements for selecting Installation Materials

It is suggested to use PPR pipe as the hot water system pipelines. PPR pipes can be easily installed and connected, the material and fittings can be expediently purchased; it will not produce welding slag or other waste materials during the installation, and will not product rust and course bad water quality during the using of unit.

The design pressure of polypropylene random copolymer pp-r (PP-R) pipeline system should not be greater than 1.0 MPa, and design temperature should not be less than 0°C and should not be higher than 70°C.

1) Heat-insulating materials and their products must have product quality6 inspection report and leave factory certificate of qualification.

2) Heat insulating material is suggested to use flexible close type foaming rubber and plastic heat insulating material;

3) Burning rating of heat insulating material is required to be B1 level or A level;

4) Refractoriness of heat insulating should not be less than 120°C.

Communication wire and control wire should strictly abide by the requirement that should use the originally provided twisted-pair or STP of unit. The standard length of communication wire between unit and wired controller is 8 meters, the maximum connecting length should not be more than 20 meters.

The power cord must use copper conductor that should comply with related local conductor standard, and satisfy current-carrying capacity requirement of unit. For specific selection of wire diameter please refer to the contents of Chapter Six.

3. Installation for Main Unit of Water Heater

3.1 External Dimensions and Size of Installation Holes

(1) External dimensions and size of installation holes for GRS-Cm28/NaA-M、GRS-Cm28/NaA1-M、GRS-Cm36/NaA-M、GRS-Cm36/NaA1-M:

Unit: mm

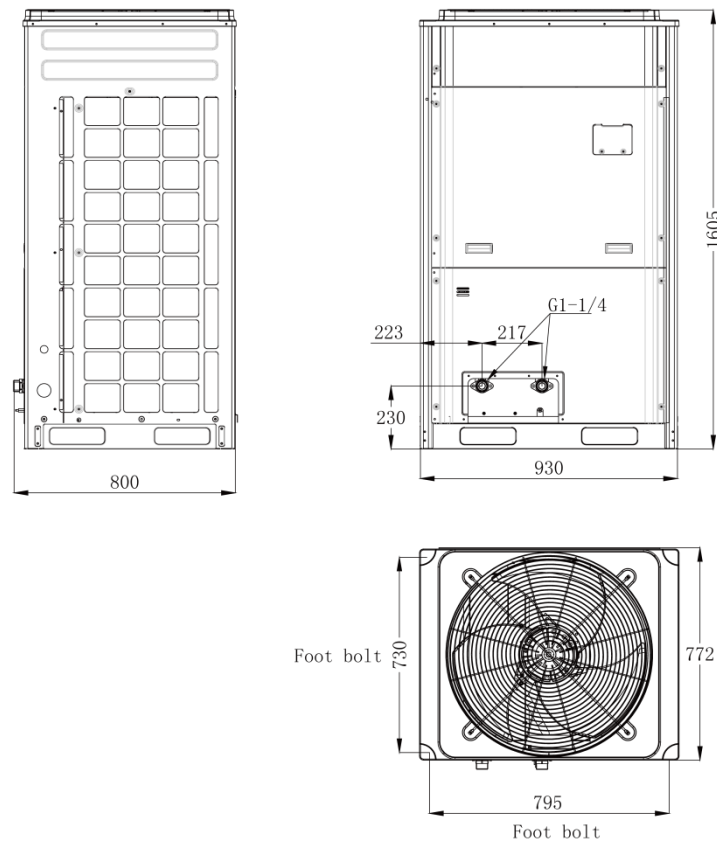

(2) External dimensions and size of installation holes for GRS-Cm53/NaA-M、GRS-Cm53/NaA1-M:

Unit: mm

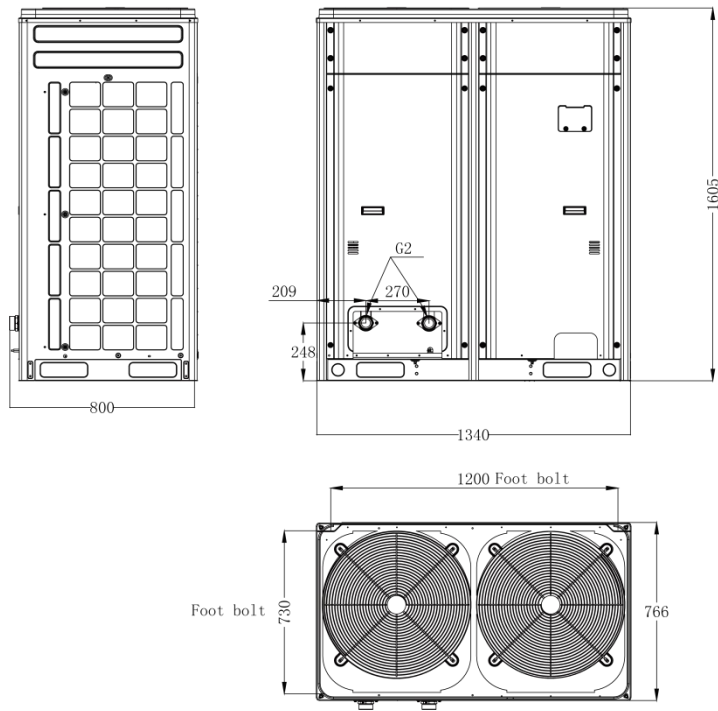

3.2 Selection of Installation Position

- 1) The installation position must be strong enough to bear the weight of water heater, and the operating noise, discharging air, and condensate water shall not affect the neighbors.
- 2) The unit should not be installed in the place with flammable and combustible materials or flammable and combustible gases.
- 3) The unit should not be installed in the place with corrosive gas, severe dust, or salt mist, etc.
- 4) The unit should be installed in the place where has good ventilation and has adequate space for air inlet and maintenance; there should be no obstacles in the air inlet or outlet for good ventilation of air.
- 5) The unit should be installed in the place where is convenient for installing connecting pipe and electricity.

3.3 Installation Space Requirement

(1) Installation space for GRS-Cm28/NaA-M、GRS-Cm28/NaA1-M、GRS-Cm36/NaA-M、GRS-Cm36/NaA1-M、GRS-Cm53/NaA-M、GRS-Cm53/NaA1-M units (Unit: mm):

- Single Installation

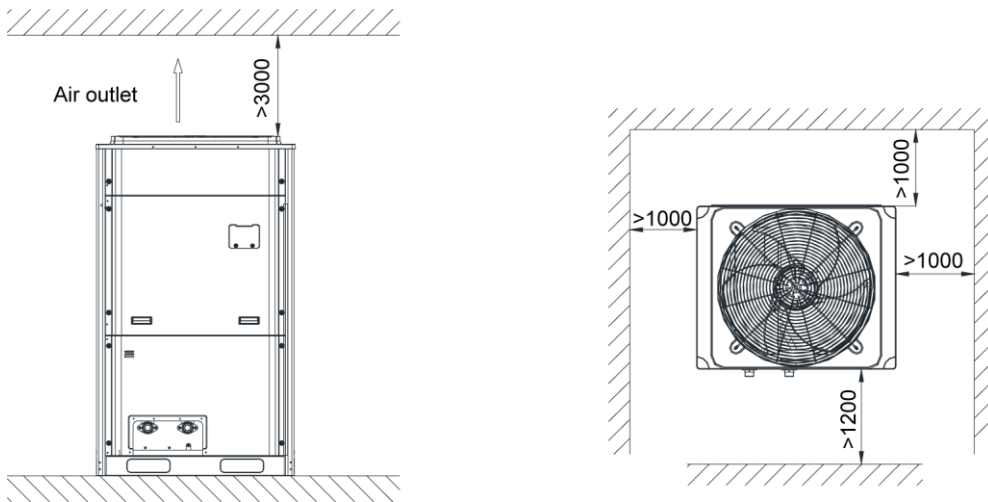

- multiple installation

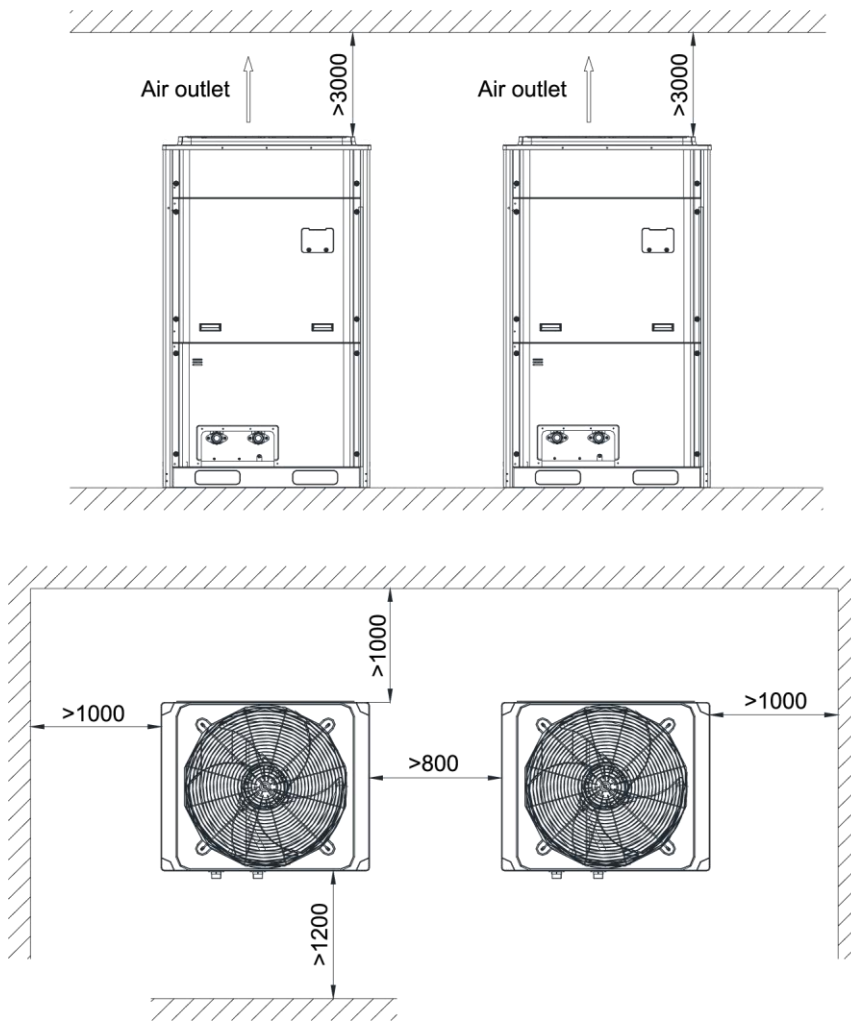

3.4 Manufacture of Installation Base

The concrete base in the installing place of outdoor unit should have enough strength, and the drainage should be in good condition that should not influence the drainage of floor or the drainage of the downstairs.

Methods for making a concrete base are as following:

- 1) The concrete base should have enough rigidity and intensity to bear the operating weight with a flat surface and 200~300mm height; the base should have a proper size according to the size of unit for later maintenance;
- 2) Proportion of the concrete: ratio of cement: sand: gravel is 1:2:4, and should lay 10 reinforced bars with diameter of $\phi 10\text{mm}$ with the distance of 30mm;
- 3) The surface of base should be paved with mortar with edge angles;
- 4) If the base is constructed in a building made of concrete, the base can be made without gravels, but the surface must be roughening;
- 5) The oil stain, gravels, dirt and water inside the reserved anchor bolt holes should be cleaned out, and should install a temporary cover to protect the holes;
- 6) Drain ditch should be made around the base so as to drain the condensate water in the installing place of unit;
- 7) When installing the unit on the roof, users should check the strength of building and take a waterproof measure;
- 8) If the base is made of U-steel structure, the design structure should have enough rigidity and intensity.

3.5 Shakeproof Requirement

Before installing the water heater, it is suggested to lay the rubber gaskets with 20mm thickness and over 100mm width on the concrete base or U-steel, and then carry the water heater onto the concrete base (U-steel) to hold down the gasket.

4. Design of Water System

4.1 Matters Need Attention for Design of Water System

- 1) Calculate all the hot water demanded volume according to the actual requirement.
- 2) According to the lowest average temperature and the water temperature in the coldest season, look up the chart or curve to acquire the actual water output capacity of different units. In consideration of different accidental factors, the hot water output of water heater is calculated at

8~10 working hours per day, so as to ensure that the water heater can satisfy the hot water demand of building under the worst working condition.

3) Determine the model and quantity of unit according to the area of installing place, bearing weight and other factors.

4.2 Installation (Principal) Sketch Map

4.2.1 Introduction for functions of parts and components

1) Major functions for parts and components of system

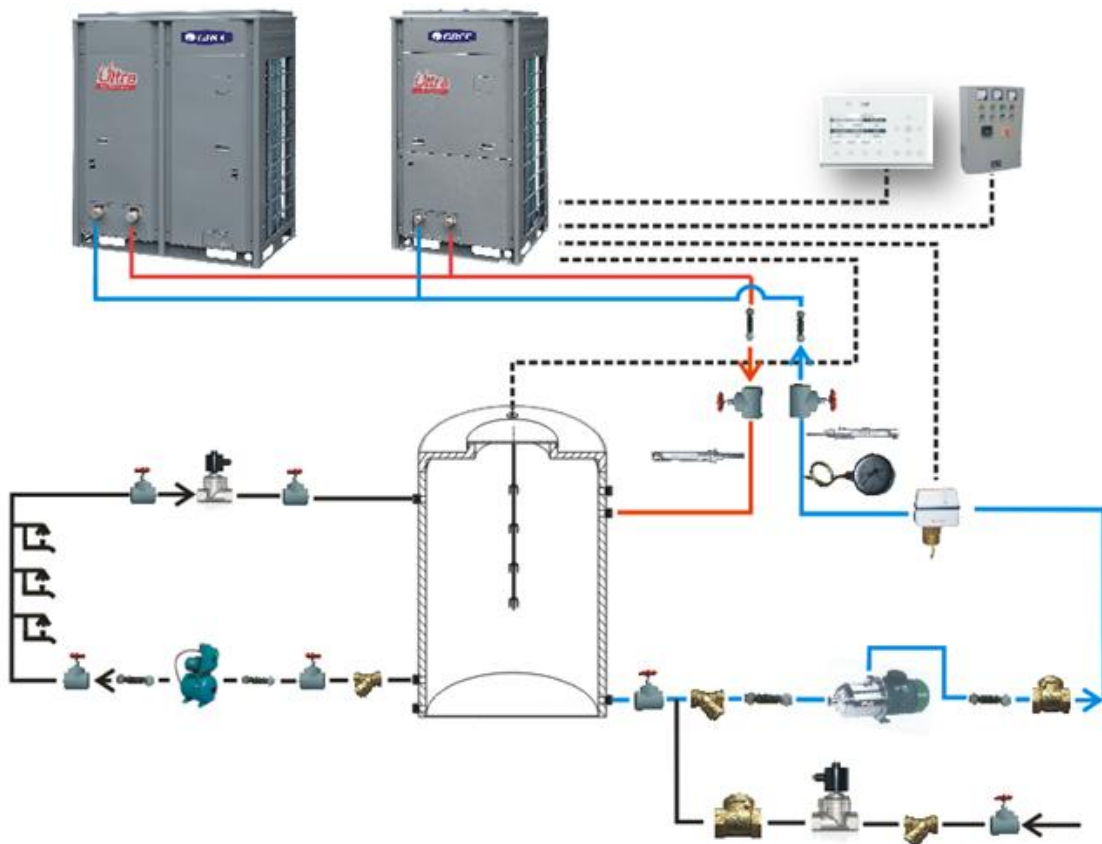

Chapter II Installation (4. Design of Water System)

No.	Name	Instruction of Function	Remarks
1	Cut-off valve	During the debugging and maintenance of unit, the cut-off valve can be manually opened and closed to control the water.	
2	Pipelines	For supplying domestic water	It is suggested to use PPR tubes and pipes
3	Filter	For filtrating the impurities inside the pipelines and preventing them from entering into the unit	
4	Flexible connector	For shock isolation, isolate the pipelines from the unit, water pump and other parts which will generate vibration	
6	Temperature gauge	For detecting the water temperature	
7	Pressure gauge	For detecting the water pressure	
8	Wired controller	Control the unit	Connect to unit
9	Electric cabinet	Supply power for the unit, water pump, etc.	It should take rainproof protection if it is placed outdoors
10	Circulating water pump	Make the water from water tank enters into the unit for heating and then return the water to water tank	It is provided by project, and is controlled by the unit;
11	Water flow switch	Detect whether the water flow inside the pipelines is enough	It is provided by project, and is connected to the unit;
12	Water tank temperature sensor	Detect the water temperature inside the water tank	It is connected to the unit; the unit is equipped with water tank temperature sensor
13	Water auto booster pump	When the water supply pressure of water using side is insufficient, the water auto booster pump can boost the pressure.	The water pump can be automatically controlled according to the pressure; if the water tank is in a relatively high position that has enough pressure to supply the water to water tap, then it can do the water auto booster pump, but the back water magnet valve in the system should be replaced with back water pump, and the back water pump is controlled by the unit.
14	Temperature sensor of user side	Detect the water temperature of user side to estimate whether there is a need to back water.	Connect to the unit, the unit or independent packing attachment has temperature sensor of user side.
15	Back water magnet valve	Control the open and close of back water pipeline; when it needs backwater, open the valve.	Controlled by the unit
16	Water level switch	Detect the water level inside the water tank, estimate whether it needs to supply water.	Controlled by the unit
17	Water tank	For storage of hot water	Water tank as hot water storage tank

No.	Name	Instruction of Function	Remarks
18	Check valve	Prevent water from back flowing	
19	Water release magnetic valve	Transfer the high-temperature hot water in the heating water tank to the hot water storage tank for use	Controlled by the unit; if the hot water in the heating water tank cannot flow into hot water storage tank through gravity, the water release magnetic valve should be replaced with water pump.

4.2.2 Requirements for Connection



Notes:

- (1) In the water inlet pipeline system of the unit, there should install a water filter with over 30 holes to prevent blockage of double-pipe heat exchanger and damage of unit. The filter should be washed regularly.
- (2) After selecting water pipe, calculate the water power. If the resistance force of water side pipes is greater than the delivery lift of selected water pump, reselect a larger water pump, or replace the water pipe with a larger size.
- (3) After leak detection is checked to be passed, the inlet water pipe and outlet water pipe of the system must have heat insulation protection to prevent loss of heat and frost crack of pipe in winter.
- (4) When the ambient temperature in winter is too low or the unit will not be started for long (24 hours), energize the unit first for not less than 8 hours before starting up the unit.
- (5) When the outdoor temperature is relatively low in winter, do not cut off the power source after the unit is closed down, otherwise the auto anti-frost operation protecting will lose its effect.
- (6) When the unit will not be used for long, please drain the water inside the unit, water tank and pipelines through draw off valve.
- (7) There should be effective earth connection devices in the water heater, hot water storage tank, pipelines before and behind the water pump, and water supply pipe network.
- (8) When selecting unit model of circulating water pump, please ensure that the circulating water flow volume of unit should not be less than the following stipulated value:

Sheet 3 Circulating Heat Insulation Flow Volume Requirements

Unit Model	Circulating Heat Insulation Flow Volume (m ³ /h)
GRS-Cm28/NaA-M GRS-Cm28/NaA1-M	≥4.8
GRS-Cm36/NaA-M GRS-Cm36/NaA1-M	≥6.2
GRS-Cm53/NaA-M GRS-Cm53/NaA1-M	≥9.2

◆ Installation Sketch Map of Single Unit System:

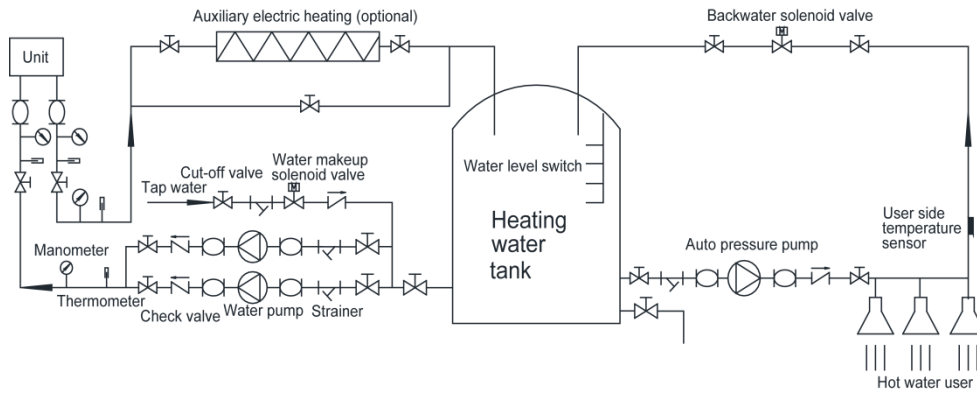

◆ Installation Sketch Mpa of Modularized System

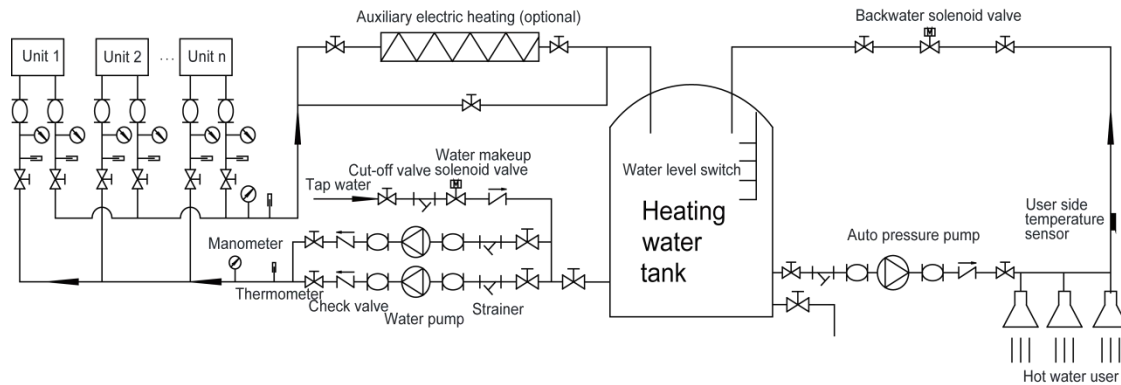

Notes:

- ① When the unit is installed lower than the water tank, then the height difference between the water tank and the unit should not be larger than 8m, otherwise there should install an intermediate transitive water tank; if the unit is installed higher than the water tank, pay attention to the model selection of circulating water pump, ensure that the single unit circulating flow volume should not be less than the value stipulated in Sheet 3.
- ② Water temperature in the booster pump, circulating pump, water supply/back water pump should not be less than 60°C.
- ③ Generally the inlet water is tap water, the water inlet should be installed with a filter (with over 30 filter holes) to prevent the impurities from entering into the unit. If the water quality is bad, then it should install an electronic hydrotreater to ensure the good water quality.
- ④ Circulating heat insulation: when the temperature detected by the temperature sensor of water tank is lower than the set temperature, circulating heat insulation function is started up.
- ⑤ Back water control: when the water system of user side has not been used for long, the water temperature in water pipe of the system will decrease to a certain back water setting value, the back water magnetic valve will be started, and user water supply pump is started to push the hot water in the hot water storage tank into pipeline network to make the water temperature inside the pipeline increase. When the water temperature is increased to +6°C over the set temperature or to a certain temperature that can support the backwater pump to keep operating, the backwater magnetic valve will be stopped for ensuring the water temperature requirement. The back water magnetic valve should be controlled by control leading wire of backwater pump.

⑥ When user is using water, the user water supply water pump will be controlled by the electric contact manometer or water flow switch (equipped by project). Meanwhile, they will send the power-off command to backwater solenoid valve.

⑦ Control of auxiliary electric heating: when installing the unit, it is suggested to choose auxiliary electric heating parts to satisfy the water output insufficiency of unit in winter. Model selection of auxiliary electric heater please refer to the following instructions, it should be installed in parallel with the main unit. After installing, when the main unit is steadily operated (6 minutes later after started up the unit), manually adjust the cut-off valve to adjust the water output temperature of auxiliary electric heater.

⑧ The unit needs to have heat insulation protection for preventing heat loss of hot water pipelines. When the ambient temperature is below 0°C in winter, all the water pipelines and valves should have heat insulation protection. The common thermal insulation materials are PEF, glass cotton, rubber insulation sponge, etc. The thickness of heat insulating layer should be ≥30mm.

4.3 Design and Installation of Water Tank

4.3.1 Manufacture of water tank

Installation Diagram of Water Tank

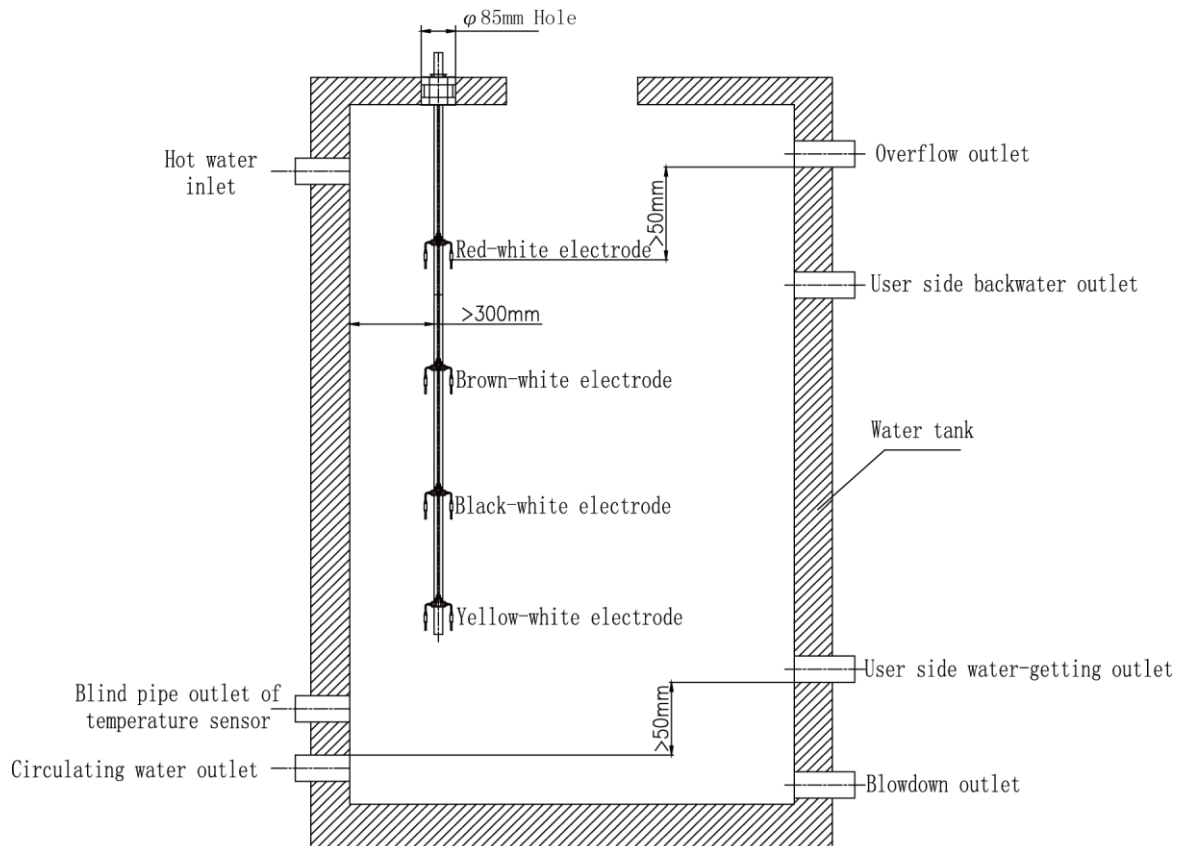

Installation diagram of water tank

The installation of water tank is mainly for the matching between water tank and pipelines

and the matching among water level switches. Please pay attention to the following points during installation:

- (1) The water-getting outlet of user should be 50mm (minimum) higher than the circulating water outlet to prevent water-lacking during operation.
- (2) The overflow port should be 50mm (maximum) higher than the water level switch to prevent overflow of water tank. The overflow port must be connected with connection pipe and then lead it to the flow drainage outlet;
- (3) The hot water inlet and the user back water outlet should point at the water level switch to prevent impacting of water flow and then cause wrong action of switch.
- (4) If the auxiliary electric heating device is installed on the water tank, the position of the auxiliary electric heating device should be lower than the user water-getting position.
- (5) Water temperature sensor must be installed under the user water-getting outlet, and it should be placed into the blind pipe.
- (6) The valid volume of water tank must be ensured. The valid volume of water tank is the volume between the user water-getting outlet and the high water level.

4.3.2 Notices for installing water tank

- 1) After the water tank is filled with water, its weight will be great, it must be placed in the ground or floor than can sustain the weight;
- 2) The water tank must be installed in the base with reliable fixation;
- 3) If the water tank is installed outdoors, it should have waterproof protection to prevent rain from entering into water tank and pollute the water quality;

5. Installation and Heat Insulation for Pipelines of Water System

5.1 Installation of Water Pipe

5.1.1 Selection of pipe material

1) The PP-R pipe materials used in the pipeline system should be manufactured from the same factory and the same raw materials, the performance should satisfy the requirement of good temperature resistance and pressure resistance.

2) The pipe materials and parts should have the valid inspection report issued by authoritative inspection unit and quality certificate issued by manufacturer. It should indicate the name of raw material, specification and trademark on the pipe, and should indicate production batch number, quantity and date of production on the package.

3) Appearance and quality of pipe materials and parts should satisfy the following

requirements:

The pipe materials and parts should be light-tight with smooth inner and outer walls, the wall thickness should be even without air bubble, scratch marks and other defects.

Interface of pipe material should be level, and the end face should be vertical to the axes of pipe.

Pipe material should be complete without defect and distortion; joint of matched moulds and gate stick should be flat without cracks. Wall thickness of pipe should not be thinner than the thickness of the same series of pipe wall.

There should be designation to identify cold water pipe and hot water pipe.

4) Dimension and size of PPR pipe series are as follows: (mm)

Nominal outer diameter dn	Average outer diameter		Pipe Series				
			S5	S4	S3.2	S2.5	S2
	Minimum	Maximum	Nominal wall thickness en				
20	20	20.3	—	2.3	2.8	3.4	4.1
25	25	25.3	2.3	2.8	3.5	4.2	5.1
32	32	32.3	2.9	3.6	4.4	5.4	6.5
40	40	40.4	3.7	4.5	5.5	6.7	8.1
50	50	50.5	4.6	5.6	6.9	8.3	10.1
63	63	63.6	5.8	7.1	8.6	10.5	12.7
75	75	75.7	6.8	8.4	10.3	12.5	15.1
90	90	90.9	8.2	10.1	12.3	15.0	18.1
110	110	111.0	10.0	12.3	15.1	18.3	22.1

Notes: The length of pipe is generally 4m or 6m; it also can be defined according to the user's requirement. The length of pipe should be no minus deviation. Wall thickness should not be less than the value stipulated in the above sheet.

Pipe series (S) is for indicating the nondimensional parameter series of pipe specification.

$$S = \frac{d_n - e_n}{2e_n}$$

In the formula: dn — nominal outer diameter, mm;

en—wall thickness, mm;

The smaller the S is, the thicker the wall will be. With the same material, the thicker the wall is, the corresponding pressure sustaining capacity will be better.

5) Selection of PP-R pipe is depending on the design pressure, working water temperature and using environment of pipeline system. Using temperature of cold water pipe is $\leq 40^\circ\text{C}$, long-term using temperature of hot water pipe is $\leq 70^\circ\text{C}$. Pipe series S of cold water pipe and hot water pipe can be selected according to the following sheet:

Type	Material	Design Pressure (MPa)		
		PD≤0.6	0.6<PD≤0.8	0.8<PD≤1.0
Cold water pipe	PP-R	S5	S4	S4
Hot water pipe	PP-R	S3.2	S2.5	S2

5.1.2 Installation for pipelines of water system

When the PP-R pipe is connected by hot welding, the welding machines and tools should be specially provided or acknowledged by pipe material manufacturers. The machines and tools for welding should be safe and reliable and easy to be handled, and should have product certificate of qualification and operating instruction manual.

Hot welding connection steps:

1) Energize the welding machine and tools, the machine can be used for welding only when it reaches the working temperature ($260\pm 10^{\circ}\text{C}$) and the indicator is on.

2) Before connecting the pipes, the end of pipe is suggested to cut 40~50mm off, when cutting the pipes, the end face should be vertical to the axial line of pipe. It is suggested to use pipe clipper or pipe cutter or hacksaw to cut the pipes, after cutting the pipes, the rough selvedge of cross section should be removed.

3) Connection end face of pipes and parts should be clean, dry and no oil.

4) Use calipers and pen to measure and mark the socket depth of pipe end, the socket depth should not be less than the requirements in the following sheet;

5) Heating time, processing time and cooling time should be conducted according to the manufacturer of hot welding machine. If there is no requirement, please refer to the following sheet:

Technical Requirement of Hot Welding Connection				
Nominal outer diameter (mm)	Minimum socket depth (mm)	Heating time (s)	Processing time (s)	Cooling time (min)
20	11.0	5	4	3
25	12.5	7	4	3
32	14.6	8	4	4
40	17.0	12	6	4
50	20.0	18	6	5
63	23.9	24	6	6
75	27.5	30	10	8
90	32.0	40	10	8
110	38.0	50	15	10

Notes: the applicable temperature of the parameter in this sheet is 20°C . If it is lower than this temperature, the heating time will be accordingly prolonged; if the ambient temperature is lower than 5°C , the heating time is suggested to be prolonged for 50%.

6) When welding the bent pipe or tee joint, pay attention to the direction of the joint, indicate

the position with auxiliary mark in the rectilinear direction of pipes according to the requirements of design drawing;

7) When connecting pipes, insert the pipe end into heating jacket to the marked depth without rotating the pipe end, and at the same time push the pipe parts to heating head where has marked;

8) When it reaches the heating time, immediately take down the pipes and parts from heating jacket and heating head, and then straightly insert them to the marked depth quickly without rotating them to form an even flange in the joint.

9) Within the stipulated processing time, the joint that has just been welded can be adjusted, but it cannot be rotated.

10) When carrying the pipes and parts, they should be well packed, should be handled with care and kept away from oil stain; it is not allowed to impinge, throw, break, roll or drag the pipes and parts.

11) The pipes and parts should be stored in the inventory or shack with good ventilation. It is not allowed to place it outdoors or under direct sunlight, keep them away from fire or heat source;

12) Pipes should be horizontally piled in clean place. The parts should be piled by layers with the height be not over 1.5m.

13) Do not use any damaged pipes or parts.

14) The mouths of pipe during installation of pipe system should be sealed or blocked in time. If there is damage, the pipes should be replaced in time.

15) During installation, the pressure level and type of pipe for cold water pipe and hot water pipe should be rechecked. The PP-R pipes of different types should not be mixed. The marks of pipes should face forth.

16) For the pipes embedding into walls, there should reserve grooves. If the size of grooves has no specific requirements, the depth of groove should be $dn + (20 \sim 30)$ mm, the width should be $dn + (40 \sim 60)$ mm. If the horizontal groove is relatively long or the depth of groove is over 1/3 of the thickness of wall, it should acquire the consent of professional technician. The surface of groove should be flat and even that has no outshoots; there should have fixture for the pipe; after the pipes have passed the pressure test, use M10 level concrete and mortar to fill up the gap. When the branch of hot water pipe is vertically embedded, the paved M10 mortar layer on the surface should not be less than 20mm;

17) When installing the pipes, there should not be axial distortion. When the pipe is penetrated to the walls or the floors, do not compulsorily adjust it. When the PP-R pipe is installed in parallel with other metal pipelines, they should keep a certain protection distance that the net distance should not be less than 100mm.

18) If the pipelines are open mounted indoors, it is suggested to install after finishing plastering the walls. The position of reserving holes and pre-embedded pipes should be rechecked before installation.

19) When the pipe penetrates through the floors, there should set sleeve for the pipe, the height of sleeve extruded above the floor should be over 50mm, and should have waterproof protection. If the pipe penetrates through the roof, there should have waterproof protection. It should set the fixing support in the front end of pipe before penetrating; when the pipe penetrates through the wall, there should set sleeve for the pipe.

20) The pipes directly embedded in the top layer of floor and walls should have conducted pressure test before sealing the gap.

21) When installing the pipes, there should set support or hanger frame according to different pipe diameters and requirements. The position should be accurate, the covering and mounting should be flat and firm.

22) The pipe clip should firmly fix the pipe, but it should not damage the surface of pipe. It is suggested to use plastic belt or rubber gasket between metal pipe clip and the pipe. When connecting metal pipe parts with PP-R pipe, the pipe clip should be set in the end of metal part.

23) There should set fixing support when installing valves, water meter, floating valve and other water supply accessories. When the fixing support is set on the pipe, the net distance with water supply accessories should not be over 100mm.

24) The minimum size of pipe clips for support and hanger frame should be determined by the pipe diameter. When the nominal outer diameter is not larger than DN50, the minimum width of pipe clip is 24mm; when the project outer diameter is DN63 and DN75, the minimum width of pipe clip is 28mm; when the nominal outer diameter is DN90 and DN110, the minimum width of pipe clip is 32mm.

25) The distance between support/hanger frame and vertical pipe/transverse pipe should not be over the following stipulated value:

Maximum Distance for Support/Hanger Frame of Cold Water Pipe (mm)									
Nominal outer diameter dn	20	25	32	40	50	63	75	90	110
Transverse pipe	600	700	800	900	1000	1100	1200	1350	1550
Vertical pipe	900	1000	1100	1300	1600	1800	2000	2200	2400

Maximum Distance for Support/Hanger Frame of Hot Water Pipe (mm)									
Nominal outer diameter dn	20	25	32	40	50	63	75	90	110
Transverse pipe	300	350	400	500	600	700	800	1200	1300
Vertical pipe	400	450	520	650	780	910	1040	1560	1700

5.1.3 Inspection of gas proofness

1) Test pressure of cold water pipe should be 1.5 times of the design pressure of cold water pipe system, and should not be less than 0.9MPa;

2) Test pressure of hot water pipe should be 2.0 times of the design pressure of hot water pipe system, and should not be less than 1.2MPa;

3) Water pressure test of pipe should satisfy the following requirements:

a. Pressure test should be conducted only after the pipe has been installed and the outward appearance is checked to be passed;

b. For the pipes are connected by welding, water pressure test should be conducted 24 hours after the connection is done;

c. Pressure test medium is clear water under normal temperature. If the pipe system is large, the test can be conducted by layer or by area;

4) For the pipes embedded in the top layer of floor or wall, pressure test should be conducted before sealing or filling up the groove. The constructor can continue to work only after it has reached the pressure test requirements. For the large construction project, pipe pressure test work can be conducted by phase according to construction schedule;

5) When conducting water pressure test in winter in cold area, there should adopt effective anti-frost measures, and should drain the pipe in time after the pressure test.

5.2 Installation of Water Flow Switch

The water flow switch is used for measuring water flow of the circulating water side. When the

circulating flow reaches its closed flow, it is used to output closed loop circuit; when water flow is smaller than a certain flow, water flow switch will send out a break-off signal to stop the units and thus protect compressor, water pump and other important components.

1) Water flow switch of water heater should be installed in the circulating inlet water pipe; it should not be installed in the hot water outlet pipe; installation size of water flow switch is G1.

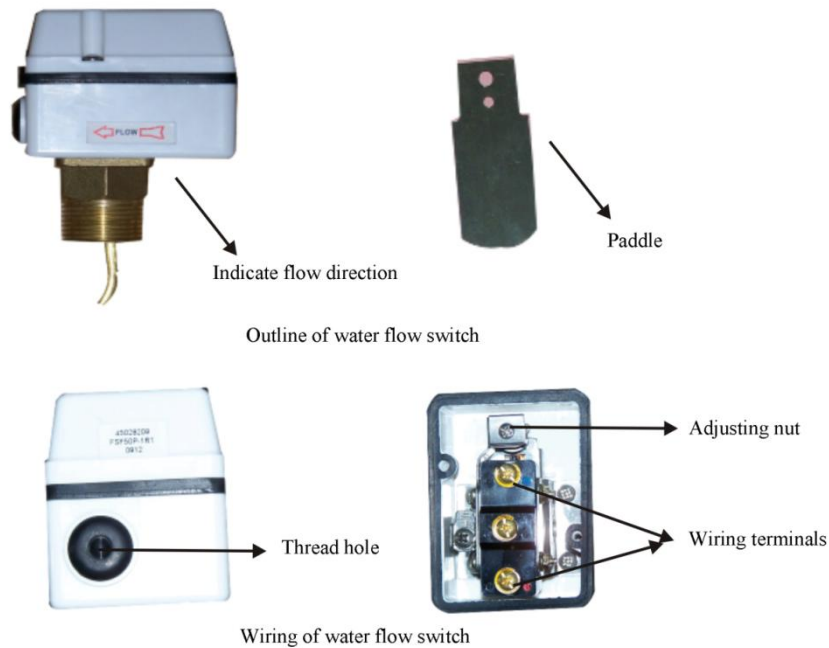

2) Usually water flow switch contains detachable paddles that are 45mm, 65mm, 75mm or 85mm's long and 16mm's wide. The paddle can be trimmed conditionally during installation. Please make sure the rear part forms an arc that matches the pipe and the bottom of the paddle should be 10%-20% above the pipe central line, thus avoiding collision between the paddle and the inner surface of pipes as well as other objects inside.

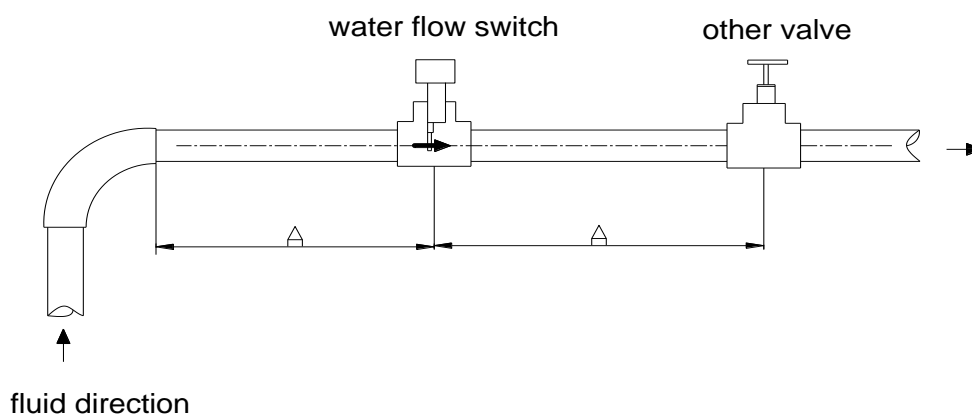

3) Please make sure that the flow direction is consistent with the marks on the water flow switch box cover;

4) Water flow switch should be installed on horizontal pipes, and make sure that size of A in above diagram is at least 5 times larger than pipe caliber;

5) The wiring distance between the water flow switch and the units should be less than 10m, and the water flow switch should be installed at a position where wiring is easy;

6) Water flow switch project should have corresponding rain-proof equipment (rainproof cover should be set up).

5.3 Installation of Water Level Switch

5.3.1 Installation of Electrode Type Water Level Switch

Gree commercial water heater adopts 4-level water level switch and one-level water level switch. 4-level water level switch is applied in heating water tank and one-level water level switch is applied in heat-accumulating water tank. If the system is not installed with heat-accumulating water tank, one-level water level switch is not needed.

5.3.1.1 4-level Water Level Switch

(1) Function Introduction

Electrode-type water level switch adopts 4-level electrode to detect water level. Various water yield can be achieved through setting different water level modes (detailed setting of water level modes please refer to Sheet 1), in order to achieve the function of controlling water makeup.

(2) Operation Introduction

① Introduction of Wired Controller Interface

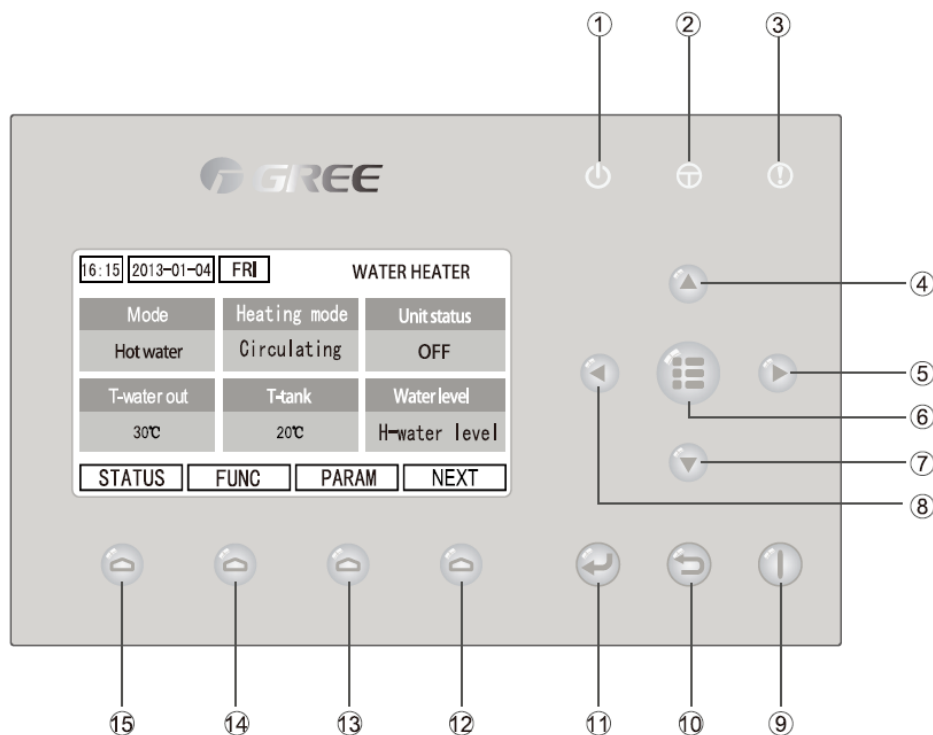

















Fig.1

Sheet 1

No.	Icon	Name	No.	Icon	Name
1		Operation indicator	9		On/Off button
2		Power indicator	10		Exit/Return button
3		Error indicator	11		Confirm button
4		Up button	12		Functional button 4
5		Right button	13		Functional button 3
6		Menu button	14		Functional button 2
7		Down button	15		Functional button 1
8		Left button			

Main menu interface 1

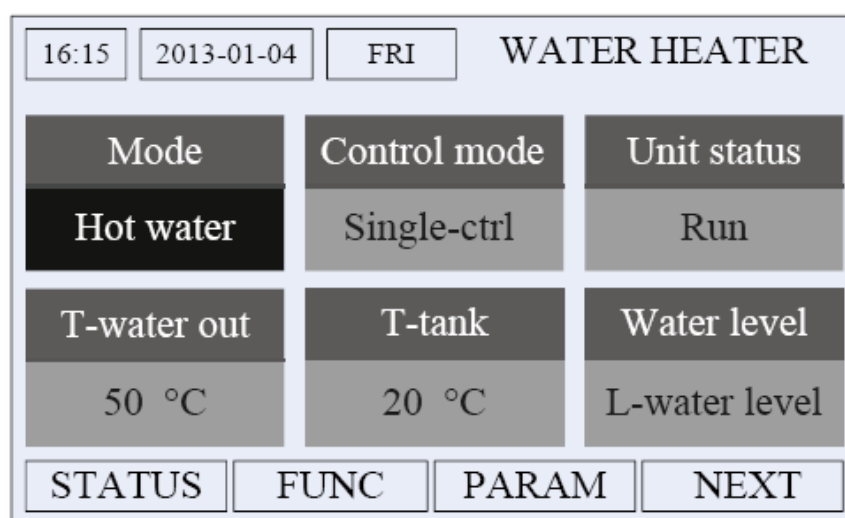

Fig.2

② Setting of Water Level:

When the wired controller is in the main interface, press Functional button 3 to enter user parameters setting interface, as shown in the figure:

16:15	2013-01-04	FRI	USER PARAM
T-out water	Cyclic temp	Water level	
Enter	46 °C	02	
T-E heater on	T-E heater off	T-return water	
10 °C	55°C	35°C	
RESET	SAVE	ENGIN	NEXT

Fig.3

After entering user parameters setting menu, hold on pressing Right button to enter water level setting mode; hold on pressing ▲ button or ▼ button to adjust parameter value continuously. There are six kinds of water level mode for option. For example, when water level mode is set in 02, the corresponding electrode in water tank is No. 4 and No. 2. The setting will be valid after saving setting.

Sheet 2 Water Level Modes

Water level mode	High water level	Medium water level	Water yield
01	#4 electrode	#3 electrode	100%
02	#4 electrode	#2 electrode	
03	#4 electrode	#1 electrode	
04	#3 electrode	#2 electrode	75%
05	#3 electrode	#1 electrode	
06	#2 electrode	#1 electrode	50%

③ Detecting Electrode

Detecting electrode has 4 pieces of signal wire. They are red&white wire of #4 detecting electrode (100% water level line), brown&white wire of #3 detecting electrode (75% water level switch), black&white wire of #2 detecting electrode (50% water level line) and yellow-white wire of #1 detecting electrode (25% water level line).

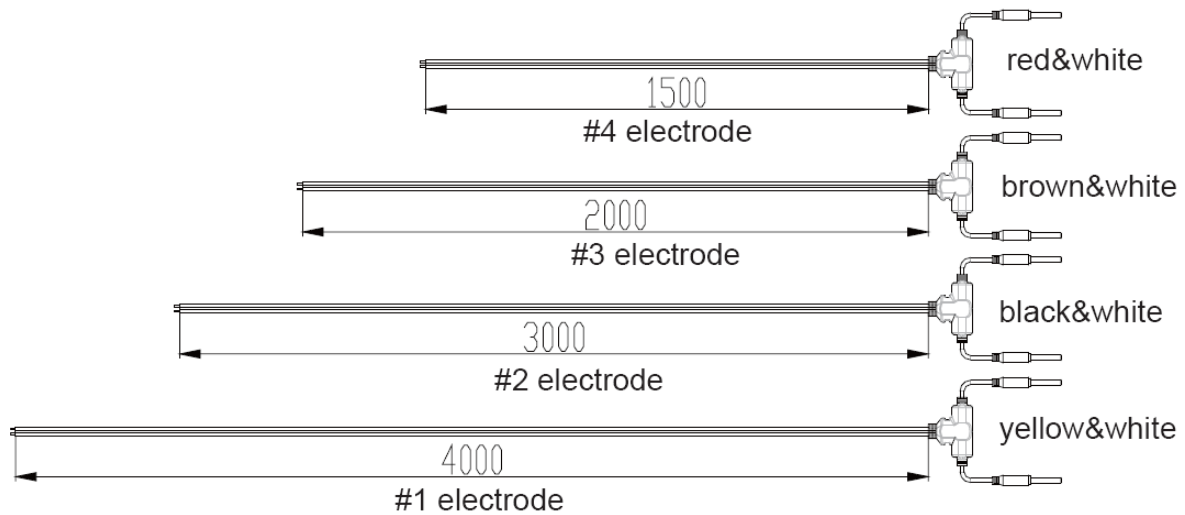

Fig.4



Notices:

- ◆ The detecting signal wire must be connected to the corresponding water level according to the color. Otherwise, it may lead to damage of unit or water overflow;
- ◆ The signal wire and heavy current wire cannot go through in the same wire tube;
- ◆ Prohibit using the detecting electrode of other brands. Otherwise, it will affect the normal operation of controller;
- ◆ It is suggested to clean the detecting electrode every three months in order to remove the scale on its surface. The cleaning period can be shortened or prolonged according to the scale accumulating status in order to avoid affecting the detection of water level.

(3) Internal Wiring Diagram

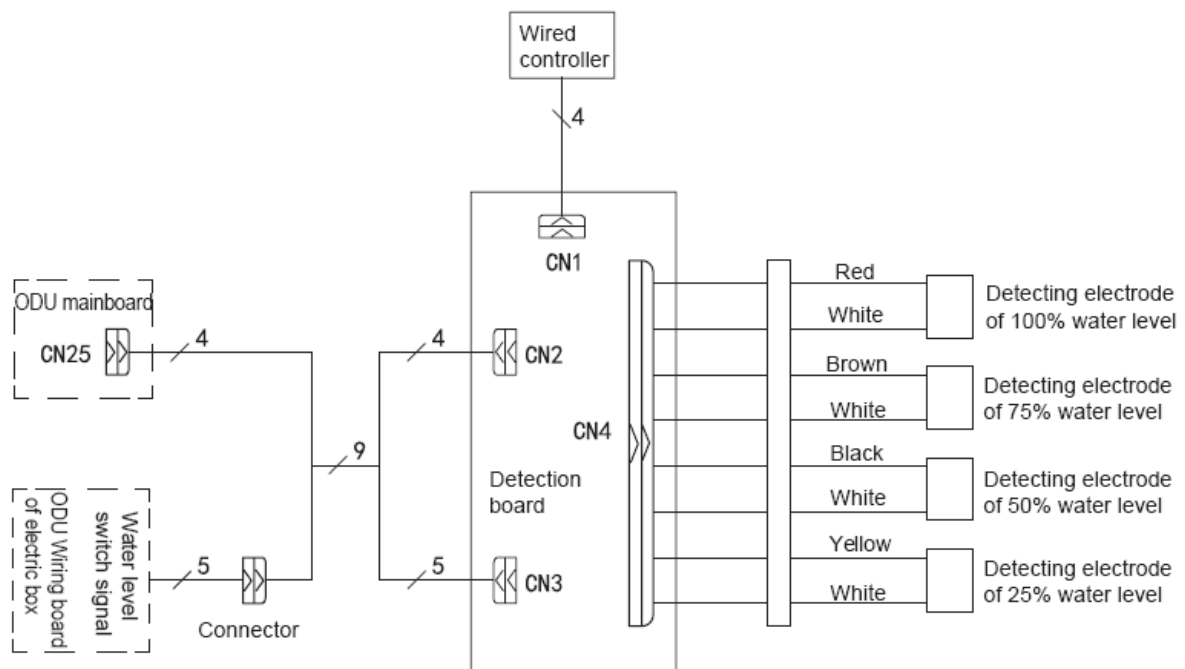

Fig.5

Note: 4, 5, 9 in the diagram mean the quantity of wire core.

(4) Wiring Way of Water Level Detection

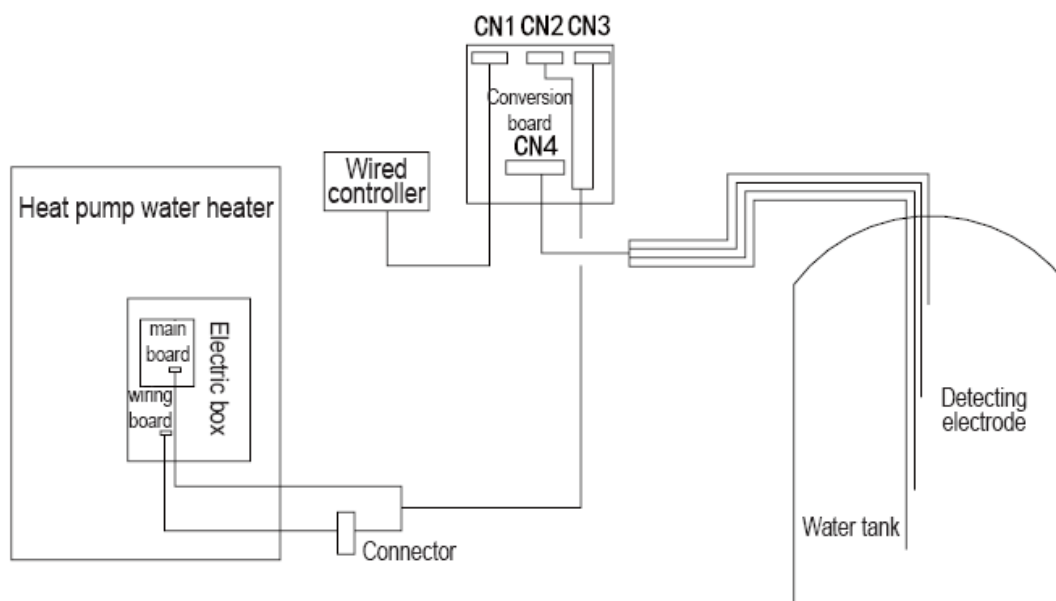

Fig.6

(5) Installation Dimension of Wiring Box

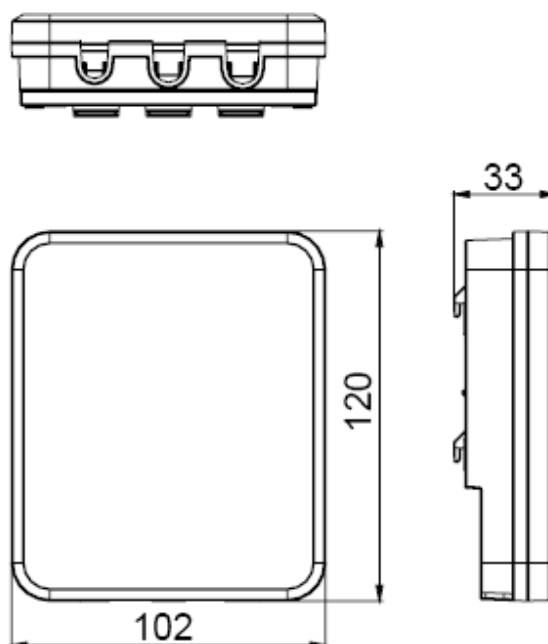

Fig.7



(6) Error and Solution

- ① Please confirm if the detecting signal wire, communication wire or water level switch wire is connected;
- ② Take the electrode out from the water tank. Wipe each electrode metal head to remove the impurities on the surface and then put it back to the water to see if the error is eliminated. If the error is eliminated, please pay attention to the routine maintenance of electrode and clean the electrode once a month.
- ③ If the error still exists when the above operation is done, please contact our after-sales

service staff.

(7) Installation Example

Rated accessories

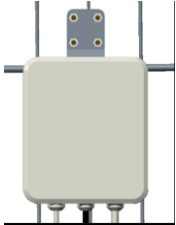
Wired controller	Detection board	Detecting electrode (totally 4 piece in the color of red, brown, black and yellow)	Wiring box
			

① The wiring inside the wiring box has been done. Please refer to the following diagram if you want to check.

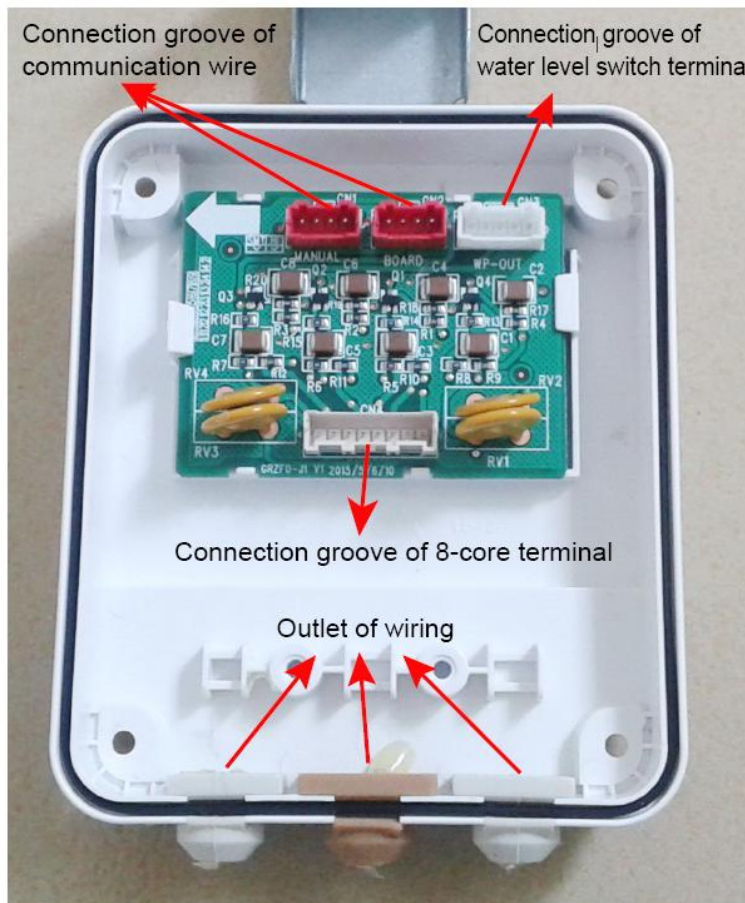

Fig.8

Then close the cover of wiring box and tighten the screws.

② Put the wiring box on the grille of unit and then fix it with U-type bolt (shown as below)

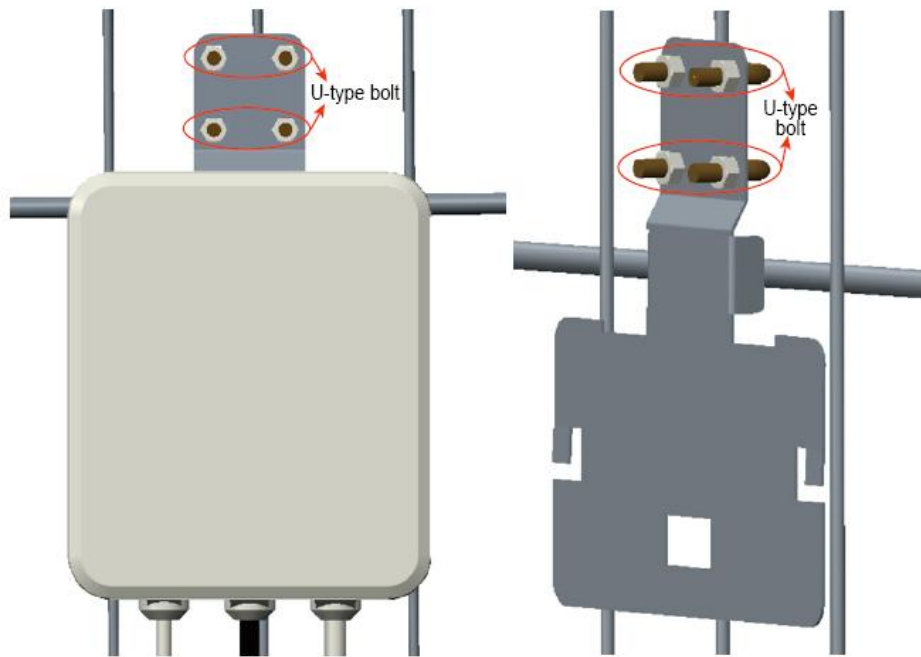

Fig.9

③ Finally, put the non-metal rod vertically into the water tank and fix it. From bottom to top, the sequence is #1 detecting electrode, #2 detecting electrode, #3 detecting electrode, #4 detecting electrode. The distance between each electrode shall be the same and this distance shall be defined according to the actual size of water tank (it is suggested to keep a distance of at least 300mm between each electrode). The highest point of electrode shall be lower than the overflow port and the lowest point of electrode shall be higher than the water-getting point.



Fig.10

(8) Installation Notices

- ① The water level switch must be installed according to the installation manual or wiring diagram;
- ② Please install the water level switch vertically and make sure the wire-outlet hole is lower;
- ③ Do not install the water level switch box in the humid environment to avoid detection failure;
- ④ During installation and operation, the connector of water level switch wire shall not be dipped into the water and shall not be hung inside the water tank to avoid failure;
- ⑤ During installation, the distance between electrode top of detecting electrode and the inner pot or bottom of water tank should be 100mm above;

5.3.1.2 One-level Water Level Switch

(1) Installation sketch map

The outline sketch map of one-level water level switch is as shown below. When the float of water level switch contact with the upper end (OFF), signal circuit will be cut off, which means water level is in high level(used for controlling high water level). when the float of water level switch contacts with the lower end(ON), signal circuit will be put through, which means water level is in low level(used for controlling low water level).

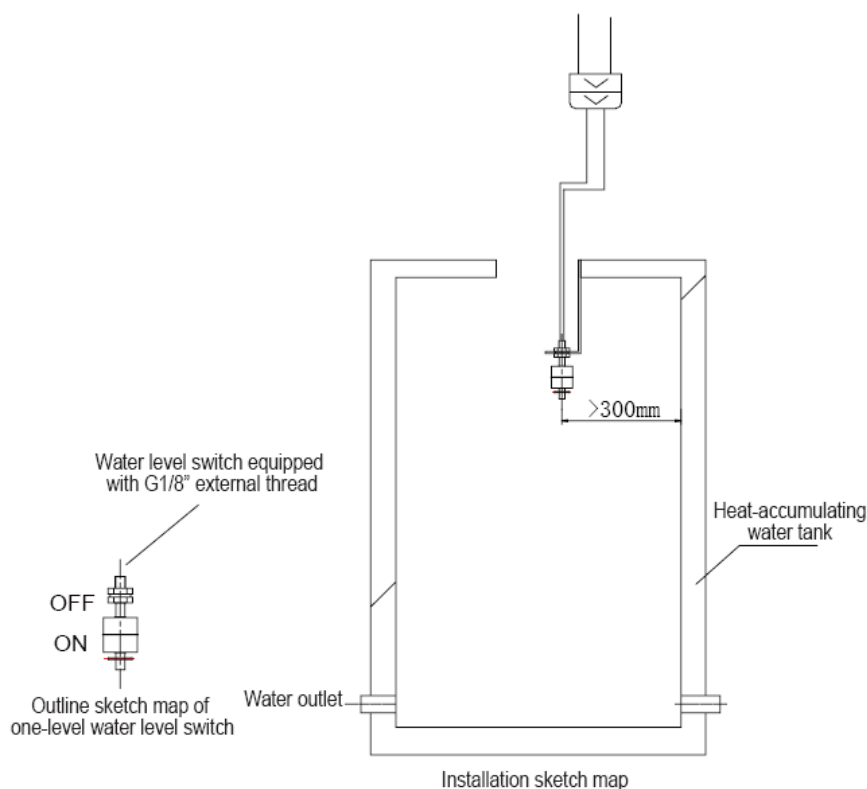

Fig.11

(2) Installation Notes:

- ① When installing water level switch, please follow installation sketch map strictly. One-level water level switch is equipped with G1/8" external thread and nut, and also one L-type sheet metal piece (can be fixed on the water tank). The water level switch can be tightened on the L-type sheet metal piece directly with nut, which is quite convenient. Horizontal installation or large-angle inclination installation are prohibited, otherwise failure or malfunction of water level switch may be caused and affect normal operation of unit.
- ② The distance between water level switch and its surrounding objects shall be not less than 300mm, in order to ensure normal operation of float. Otherwise, unit malfunction during operation will be caused and damage the unit.
- ③ Hot water inlet and backwater inlet at user's side can't face water level switch, in order to prevent inlet water flow from striking water level float and causing malfunction of water level switch.

5.4 Heat Insulation Measures

1) Earth covering depth for the embedded leading pipes of construction should not be lower than the depth of frost line, and should not be less than 500mm;

2) Note to take anti-frost measures when the PP-R pipes are installed in cold areas. Users should take heat insulation measures both indoors and outdoors, the heat insulating thickness should be defined by calculation according to the pipe diameter, thermal conductivity of heat insulating material and ambient temperature, users can select by referring to the heat insulating requirement of steel pipe;

3) The pipes installed outdoors should not be exposed under direct sunlight, or take shielding

measures.

4) The heat insulating measures can conduct by referring to heat insulating measures of steel pipes

Nominal outer diameter dn	20~32	40~50	63~90	110
Heat insulating material	Obturator foramen foaming rubber and plastic heat insulating pipe			
Thickness for heat insulating mm	25	30	35	40

6. Electric Installation

6.1 Safety Notices



Warning: All electric work must be conducted according to local law, regulation and instruction manual by professional person.



Caution: Energize the unit only after all the installations have been done.

1) Before starting up the unit, please check if the power source is consistent with the power source stipulated in the nameplate; check if the connection of electrical wire and pipelines are correct, so as to avoid water leakage, refrigerant leakage, electric shock, fire hazard and other accidents.

2) Heat pump water heater belongs to I class electric appliance, users must ensure that the water heater is grounded reliably, otherwise it may cause electric shock. The earth connection should not be connected to the wires of gas pipe, water supply pipe, lightning rod or telephone line.

3) After installing the unit, user should energize the unit and conduct creepage detection to ensure safety.

4) Once the water heater is started up, it should not be closed down until operating it for over 6 minutes, otherwise it may impact the service life of unit. Please do not turn on and turn off the unit frequently.

5) Please do not operate the water heater with wet hands. Do not allow children to operate the unit. When cleaning up the unit, please disconnect the general supply of unit first.

6) Please do not directly expose the water heater under wet or corrosive environment.

7) When the outdoor temperature is relatively low in winter, it is not allowed to cut off the

power supply after closing down the unit, otherwise the auto anti-frost protection will be invalid.

6.2 Installation of Power Source

6.2.1 Operating procedures for installing power cord

- 1) The air source water heater belongs to I class electric appliance, all electric work must be conducted according to national wiring rules by professional person.
- 2) The power source must be the power source with rated voltage or special for the unit.
- 3) The power cord should be set in electric diagram slot or electric wire tube.
- 4) After the power cord threads through the pass wire orifice, it should install a pass wire rubber loop to avoid friction between power cord and sheet metal. When the power cord is connected into electric box of unit, please use rubber or plastic to protect the power cord from being abraded by sheet metal.
- 5) There should be reliable fixture for the power cord to prevent the connecting terminal from being stressed.

6.2.2 Selection for diameter of power cord and air switch

Configuration Table of Power Source

Model	Type of Power Source	Minimum Sectional Area of Power Cord (mm ²)			Capacity of Air Switch
		Phase Line	Zero Line	Earth Wire	(A)
GRS-Cm28/NaA-M GRS-Cm28/NaA1-M	380V-415V 3N~ 50Hz	2.5	2.5	2.5	25
GRS-Cm36/NaA-M GRS-Cm36/NaA1-M	380V-415V 3N~ 50Hz	4.0	4.0	4.0	32
GRS-Cm53/NaA-M GRS-Cm53/NaA1-M	380V-415V 3N~ 50Hz	6	6	6	40

Notes:

- ① The circuit breaker and power cord is selected according to the maximum power (maximum current) of unit.
- ② The specification of power cord in the above table is based on providing the using ambient temperature is 40°C, and is under the conditions that it adopts multi-core copper cable (such as YJV copper core electric power cable) to arrange in the wire groove with working temperature of 90°C. If it is not under the aforesaid using conditions, please adjust

according to the national standard.

- ③ The specification of circuit breaker in the above table is based on the conditions that the ambient temperature is 40°C, the air switch is “D”. If it is not under the aforesaid conditions, please adjust according to the specification manual of circuit breaker.
- ④ If the length of power cord is more than 15m, please properly increase the sectional area of power cord to prevent overcurrent.
- ⑤ The capacity of air switch and diameter of power cord have not taken the external connection of auxiliary electric heater into consideration.
- ⑥ The yellow-green wire inside the unit is the earth wire. Do not connect the earth wire to following places:
 - a. tap water pipe
 - b. gas pipe
 - c. blow-off pipe
 - d. unreliable places.

⑦ Safety notices for using water

Please use PPR plastic pipe to connect to direct hot water inlet, circulating water inlet and water outlet respectively, and then connect to the exterior water pipe. If the plastic pipe is self-prepared by the user, then the length of plastic pipe should not be less than the following length: $L \geq 70 \times R^2$, L is the pipe length (unit: cm), R is the inner semi-diameter of pipe (unit: cm).

If user installs water pump, auxiliary electric heater and solenoid valve and other electric-charged parts, it is suggested to adopt PPR plastic pipe and length of plastic pipe from the electric-charged part to the place where human body can touch the water should satisfy the above requirements. If using metal pipe, both ends of metal pipe must be grounded reliably.

Set reliable earth device for heating water tank and water supply pipe network.

6.2.3 External wiring diagram of unit

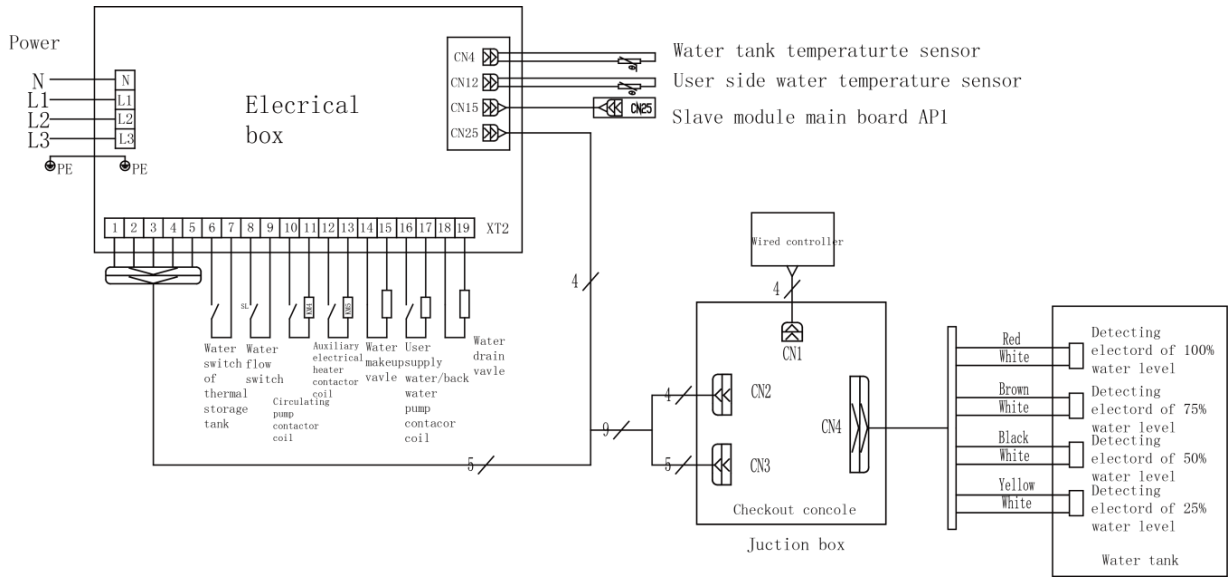

6.2.4 External wiring diagram of modularized unit

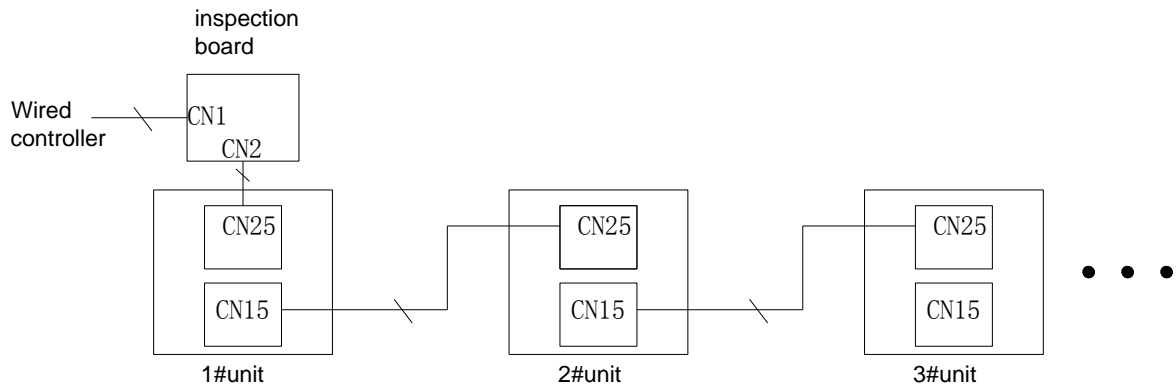

6.3 Circuit Diagram

1) Diagram of GRS-Cm28/NaA-M:

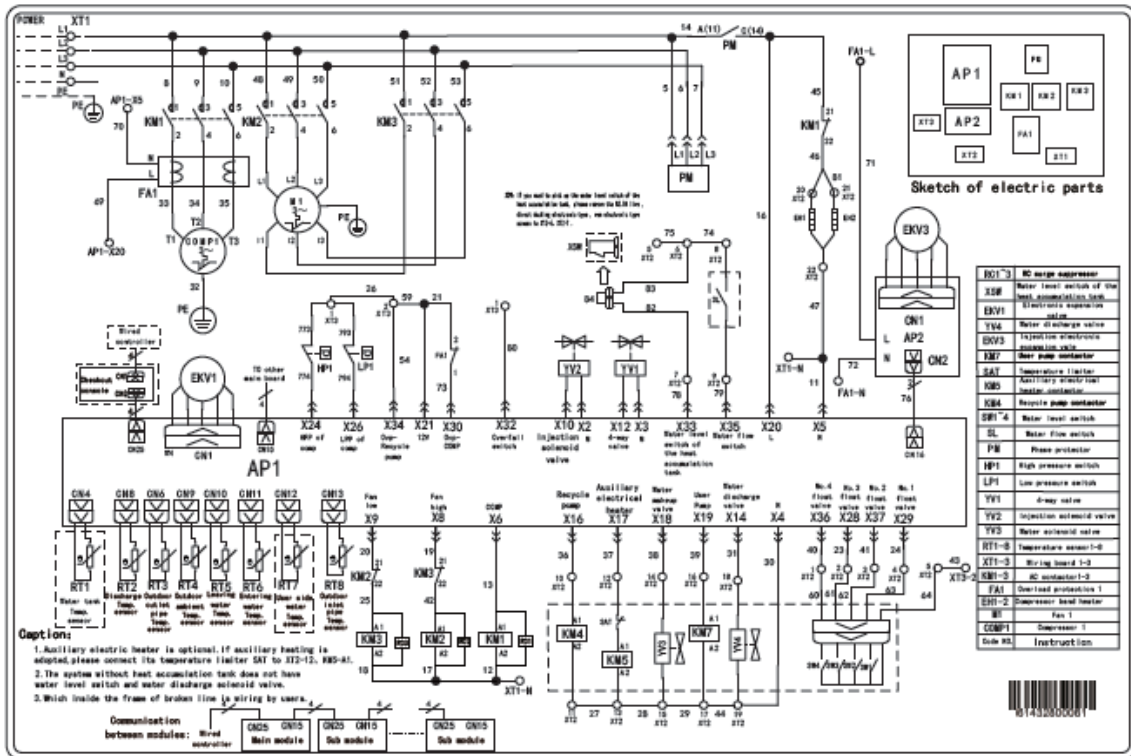

2) Circuit diagram of GRS-Cm28/NaA1-M:

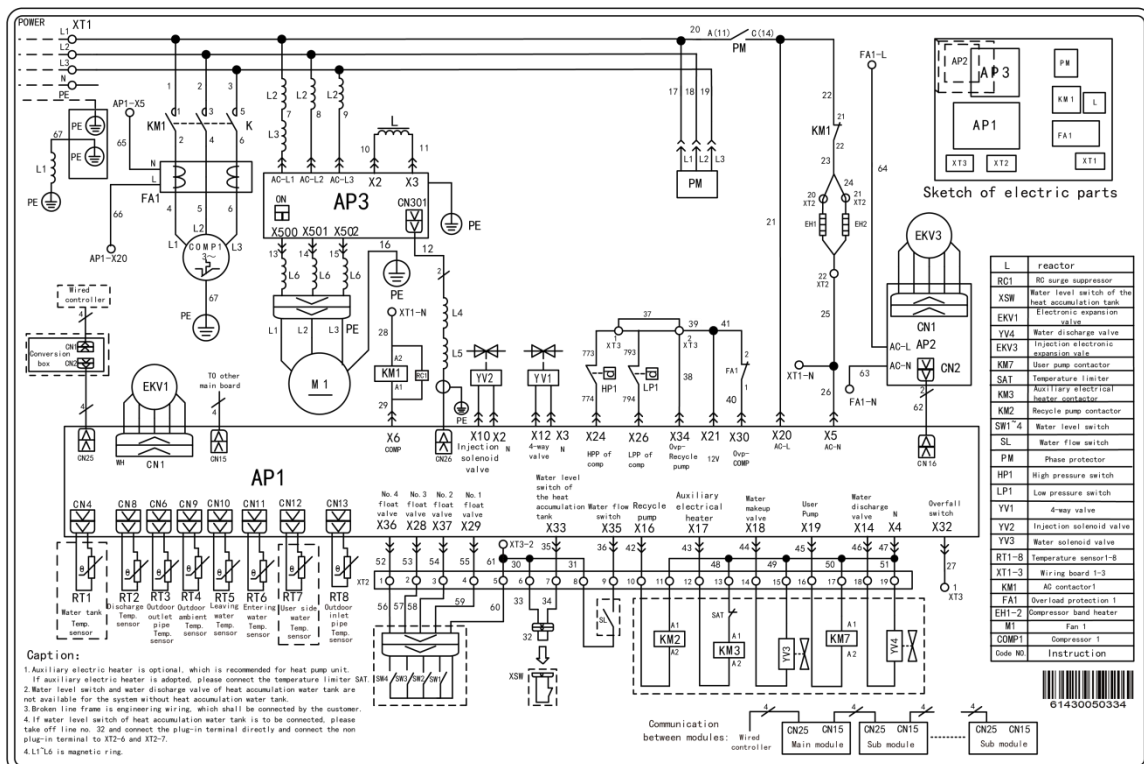

3) Circuit diagram of GRS-Cm36/NaA-M:

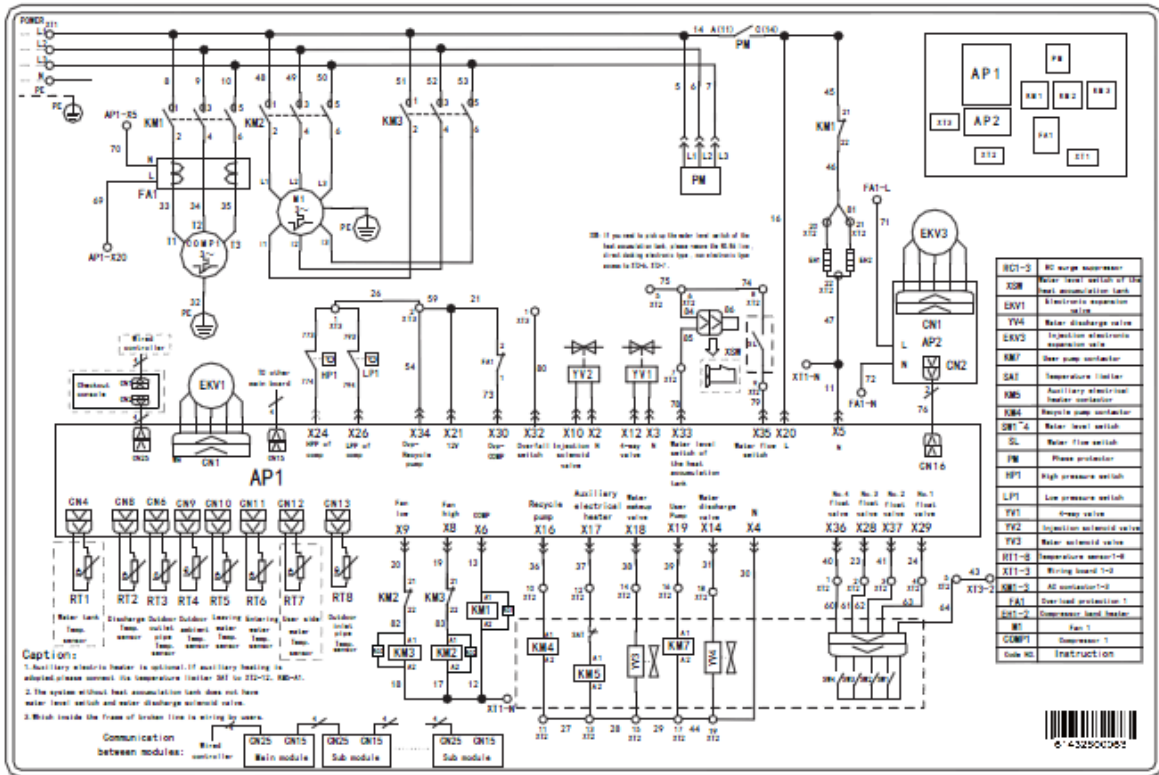

4) Circuit diagram of GRS-Cm36/NaA1-M:

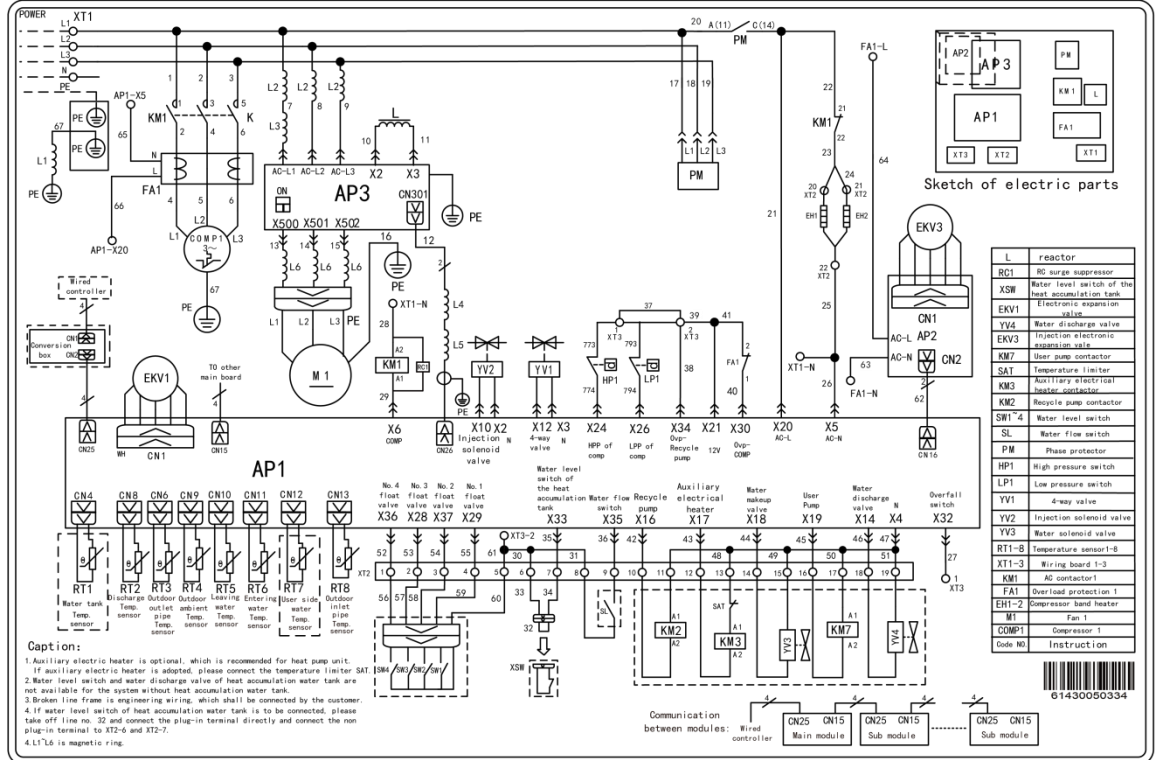

7. Installation of Communication System

This unit adopts RS485 communication method. The wired controller can control single unit, and can control multiple units as well. The wired controller has BMS interface that can connect to computer through RS232 transferring to RS485 convertor, so as to realize remote control.

7.1 Connection for Terminals of Communication Wire

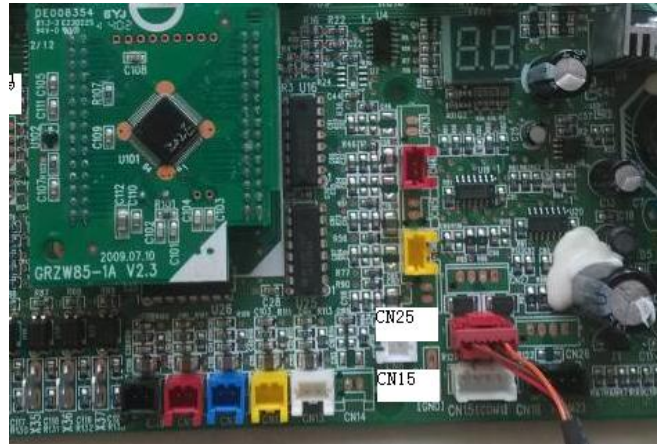

Sketch Map for Connection of Mainboard Communication Wire

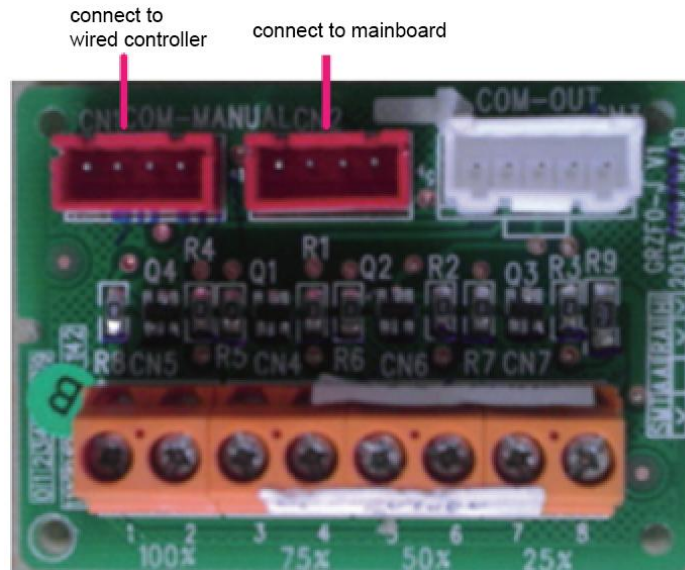

Sketch Map for Connection of Liquid Level Switch Keysets Communication Wire



Sketch map for connection of wired controller communication wire. When it needs to connect to PC, it can connect from the BMS interface.

7.2 Connecting Method for Communication Network

(It is applicable to GRS-Cm28/NaA-M, GRS-Cm28/NaA1-M, GRS-Cm36/NaA-M, GRS-Cm36/NaA1-M, GRS-Cm53/NaA-M, GRS-Cm53/NaA1-M)

7.2.1 Connecting method for single module

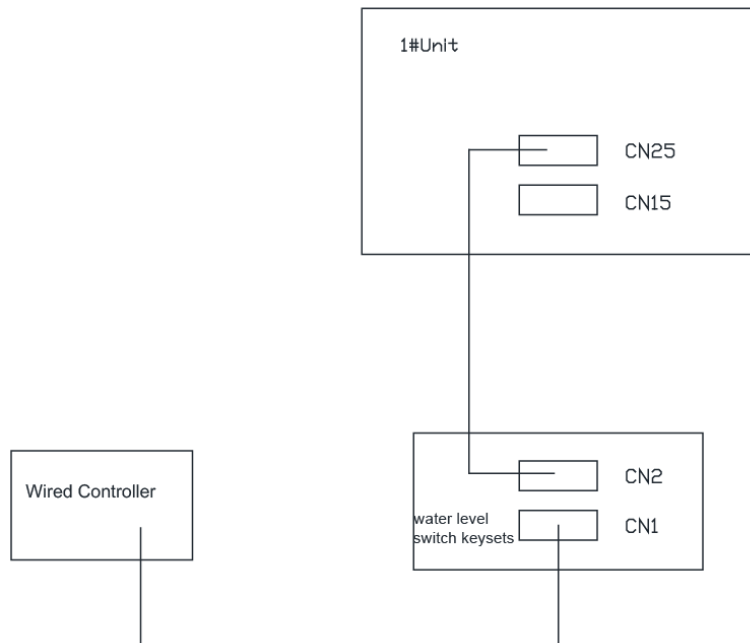

7.2.2 Connecting method for multiple module

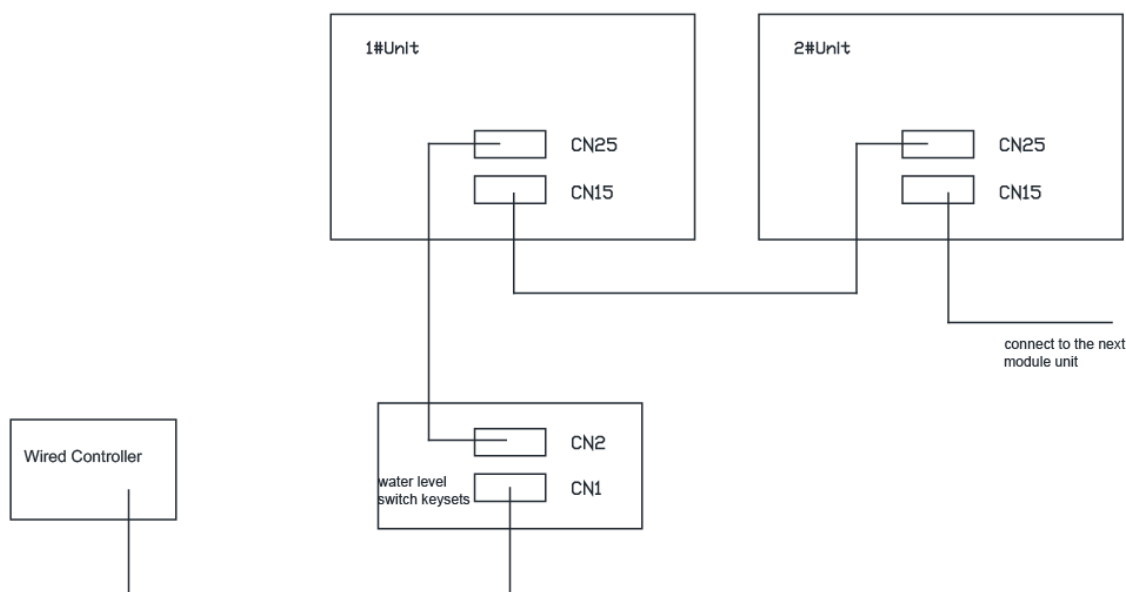

8. Charging of Refrigerant

8.1 Leak Detection of System

Generally we use soapy water to conduct lead detection. Smear soapy water to the points where are possible to leak (welding points, spools, joints, etc.), if there are bubbles, it means there is leakage, it should be welded again or repaired.

If it's difficult to detect the leaking point with soapy water, users can use electronic leak detector or charge nitrogen 20Kgf/cm² into the system and then put it into water tank to detect.

8.2 Vacuum Pumping

Vacuum pumping must be conducted with vacuum pump. Operating procedures are as follows:

- 1) Screw off the nut cap (for charging Freon) of air intake duct;
- 2) Connect the low-pressure soft tube of vacuumeter to the joint of Freon charging spout;
- 3) Connect intermediate tube of vacuumeter to pressureproof soft tube, another end of soft tube is connected to vacuum pump;
- 4) Screw up the high pressure gauge, open the low pressure gauge, and then energize the vacuum pump;
- 5) When the needle pointer of vacuumeter points at 15mmHg (gauge pressure), screw up the low pressure gauge, de-energize the unit, screw off the soft tube in Freon charging spout, and then cover the nut cap.

8.3 Recharging of Refrigerant

1) Connect the intermediate soft tube of refrigerant meter to the refrigerant tank, and connect one end of blue soft tube of low pressure gauge to Freon charging spout of air intake duct and clip it on, open the valve of refrigerant tank, and then open the valve beside the low pressure gauge of refrigerant meter to discharge for 5 seconds, screw down the joint of soft tube of refrigerant meter on the three-way valve. As shown below:

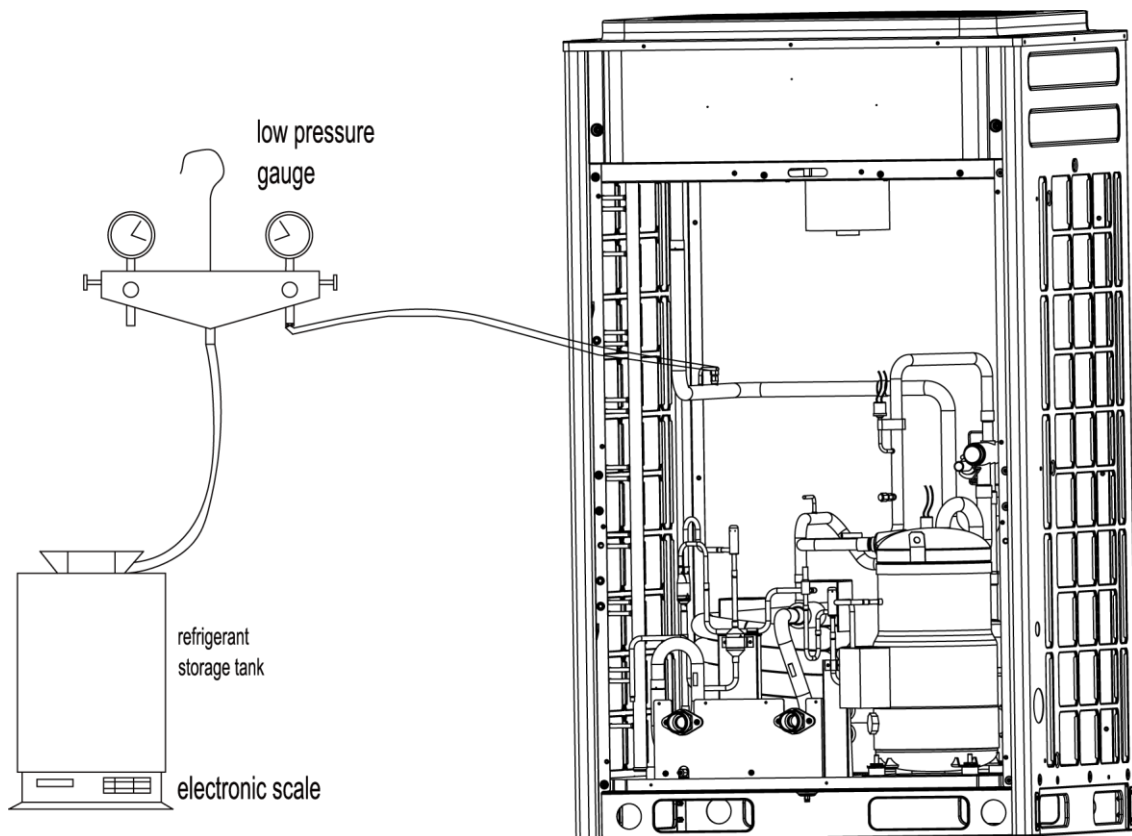

2) Wait for three minutes, after the main unit is started up, if the needle pointer of low pressure gauge rises slowly, twist off the valve beside the low pressure gauge and conduct recharging (when the low pressure gauge displays 0.8~0.85MPa, it means the charging is finished).

9. Examination After Installation

After finishing the installation, please conduct check and examination according to the following sheet.

No.	Contents for Installation	Items for Examination	Results
1	Water Heater	1) Check if the installing place of outdoor unit has good ventilation.	Pass <input type="checkbox"/> Below grade <input type="checkbox"/>
		2) Check if the outdoor unit is firmly fixed and has damping measures.	Pass <input type="checkbox"/> Below grade <input type="checkbox"/>
		3) Check if the operating noise of outdoor unit will influence the neighbors.	Pass <input type="checkbox"/> Below grade <input type="checkbox"/>
2	Water Tank	1) Check if the installing place of water tank has enough weight capacity.	Pass <input type="checkbox"/> Below grade <input type="checkbox"/>
		2) Check if the water tank is fixed reliably.	Pass <input type="checkbox"/> Below grade <input type="checkbox"/>
3	Hot Water Pipeline	1) Check if the installation of water pipes are in order.	Pass <input type="checkbox"/> Below grade <input type="checkbox"/>
		2) Check if the water system is expedite without blockage.	Pass <input type="checkbox"/> Below grade <input type="checkbox"/>
		3) Check if the model of water pump is consistent with the demand of delivery lift of flow and pipe.	Pass <input type="checkbox"/> Below grade <input type="checkbox"/>
		4) Check if the back water pipes are set according to requirement.	Pass <input type="checkbox"/> Below grade <input type="checkbox"/>
		5) Check if the pipes have been conducted gas proofness test.	Pass <input type="checkbox"/> Below grade <input type="checkbox"/>
4	Heat Insulation	1) Check if the heat insulating thickness is consistent with the requirement.	Pass <input type="checkbox"/> Below grade <input type="checkbox"/>
		2) Check if the heat insulation work of water pipes are in good condition.	Pass <input type="checkbox"/> Below grade <input type="checkbox"/>
		3) Check if the level of combustion for heat insulation material is consistent with the fireproofing requirements.	Pass <input type="checkbox"/> Below grade <input type="checkbox"/>
5	Electricity	1) Check if the unit is adopting special power source.	Pass <input type="checkbox"/> Below grade <input type="checkbox"/>
		2) Check if the power cord and air switch have satisfied the requirements of unit.	Pass <input type="checkbox"/> Below grade <input type="checkbox"/>
		3) Check if the layout of wires is reasonable. Pipe pass protection measures should be well arranged.	Pass <input type="checkbox"/> Below grade <input type="checkbox"/>
		4) Check if the power cord and communication wire are arranged separately.	Pass <input type="checkbox"/> Below grade <input type="checkbox"/>
		5) Check if the power cord, communication wire, earth wire are correctly connected according to the circuit diagram.	Pass <input type="checkbox"/> Below grade <input type="checkbox"/>
		6) Check if the installation and place of water level switch is consistent with the requirement.	Pass <input type="checkbox"/> Below grade <input type="checkbox"/>
		7) Check if the installation and place of water flow switch is consistent with the requirement.	Pass <input type="checkbox"/> Below grade <input type="checkbox"/>
Remarks			

Chapter III Debugging and Operation

1. Debugging Flow Chart

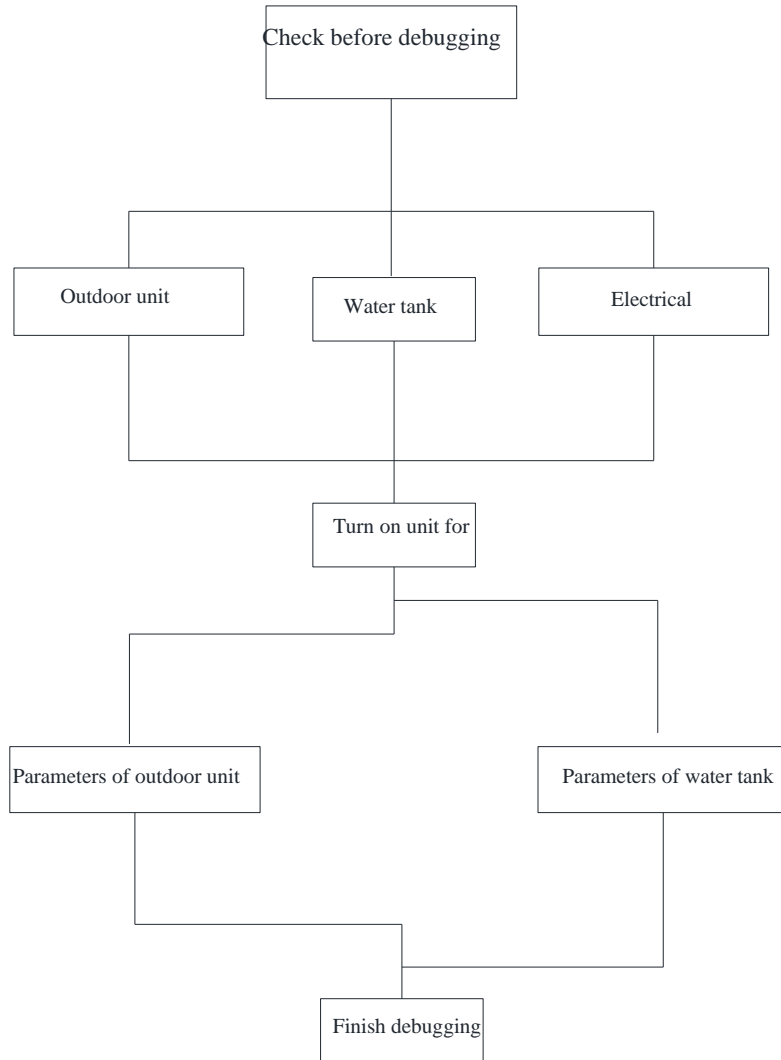

2. Safety Notices



Warning!

All commissioning and maintenance personnel must learn and strictly comply with construction security specifications. Security measures must be taken especially for outdoor operations;

Special type operators involved in the engineering implementation, such as welders, electricians, and refrigeration mechanics must have relevant operating licenses and are accredited with vocational qualification certification;

The equipment must be powered off before relevant operations, and other security requirements should be strictly complied with;

All installation and maintenance operations must comply with design requirements of this

product and national and local security operation requirements. Rule-breaking operations are prohibited;

It is forbidden to directly connect the compressor with power supply and forcibly power it on.

3. Pre-debugging Preparations

3.1 Required Tools for Debugging

- (1) Shifting spanner
- (2) Inner hexagon spanner
- (3) Straight screwdriver
- (4) Cross screwdriver
- (5) System high and low pressure gauges for corresponding refrigerants

3.2 Required Files for Debugging

Debugging data record table

Engineering project name		Unit model	
Debugging personnel		Debugging date	
Rated capacity of outdoor unit(kW)		Capacity of water tank	
Max difference between ODU and water tank(m)		Lift of pump	
Debugging status: <input type="checkbox"/> water heating			
Status parameters		Unit	Before turning on the unit
			60min
ODU status parameters	Outdoor ambient temperature	°C	
	Power supply voltage	V	
	Suction temperature	°C	
	Discharge temperature	°C	
Water tank parameters	Temperature of water outlet pipe temperature sensor	°C	
	Temperature of water tank temperature sensor	°C	
Debugging conclusion			

Spot Check for air source water heater		
No.	Spot Check Item	Qualified
Outdoor unit	Does the unit installation heat exchange space comply with requirements?	
	There should be discharge ditch or discharge outlet nearby the installation position of the unit for convenient drainage.	
	Does the height difference between outdoor unit and water tank comply with unit design requirements?	
	1) Installation foundation or support shall be firm enough to ensure stable operation of unit.	
	2) The unit shall be level after installation.	
	Does the total length of connection pipe comply with requirements?	
	Does the diameter of cables connected with IDUs and ODUs comply with unit design requirements?	
	Do the circuit breaker and leakage switch comply with unit design requirements?	
	If all power supply and control wires are connected properly?	
	If the wires are connected properly according to wiring diagram? If the unit is grounded sufficiently? If all wiring terminals are connected reliably?	
	Confirm if the current installation location has the engineering diagrams for electrical and control, etc.	
	Is the phase sequence of main power supply correct?	
Water tank	1) The installation location shall be strong enough to withstand the weight of water tank.	
	2) The drainage port of water tank shall be near the discharge ditch or discharge outlet.	
	3. If the pressure meter, pressure relief valve, auto discharge valve, etc. are installed properly.	
	4. If the water level switch, temperature sensor and controller are installed properly.	
	If the inlet pipes and outlet pipes of hot water and cold water adopt insulation pipeline.	
	If there is water overflows from the hot water faucet.	
Wired controller	1) The distance between communication wire of wired controller and heavy current wire shall be above 50mm.	
	2) The wired controller cannot be installed in high temperature and high humidity places, such as kitchen and bathroom.	
	It is suggested to install the wired controller indoors. If it is installed outdoors, an opaque rainproof protection box shall be applied in order to prevent the wired controller from direct sunshine or rain.	

3.3 Check before Debugging

3.3.1 Check for water system

1) Check if the water tank is installed reliably. If the installation location can withstand the weight of water tank when it is full.

2) Check if the insulation measure of water tank is sufficient. If the insulation measure of water inlet pipe, water outlet pipe and water supplementary pipe is sufficient.

3) Check if the water tank water level switch, temperature sensor, controller, pressure meter, pressure relief valve, auto discharge valve, etc. are installed properly. If they can work properly.

4) Check if each connection pipe, water pump, pressure meter, temperature meter, valve, etc. are installed properly.

3.3.2 Check for electrical system

1) Confirm if the current installation location has the engineering diagrams for electrical and control, etc.

2) If the power supply accords with the product nameplate. Does the electric wire model comply with related requirements?

3) If all power supply and control wires are connected properly? If the wires are connected properly according to wiring diagram? If the unit is grounded sufficiently? If all wiring terminals are connected reliably?

4) Is the phase sequence of main power supply correct? If not, please correct phase sequence according to the instruction manual.

5) Check the insulation resistance of each phase to ground and between each phase with universal meter.

3.3.3 Check for main unit location

1) The main unit shall be installed in a sufficient space with good ventilation and smooth air inlet and air outlet.

2) There should be discharge ditch or discharge outlet nearby the installation position of the unit for convenient drainage.

3) Installation foundation or support shall be firm enough to ensure stable operation of unit.

4) The unit shall be level after installation.

3.3.4 Check for water tank installation location

1) The installation location shall be strong enough to withstand the weight of water tank.

2) The drainage port of water tank shall be near the discharge ditch or discharge outlet.

3.3.5 Selection of wired controller installation location

1) The wired controller cannot be installed in high temperature and high humidity places, such as kitchen and bathroom.

2) It is suggested to install the wired controller indoors. If it is installed outdoors, an opaque rainproof protection box shall be applied in order to prevent the wired controller from direct sunshine or rain.

3) The distance between communication wire of wired controller and heavy current wire shall be above 50mm.

4. Debugging Operation

4.1 Notices for Engineering Debugging

Check the power supply specification of installation location, possible application range(connection pipe distance, high difference between IDU and ODU, power supply voltage) and installation space.

When debugging operation and everything are properly, please instruct the operation and maintenance methods to the user according to the instruction manual. Meanwhile, please hand over this notices and instruction manual to the user and ask the user to keep them properly.

4.2 Basic Introduction of Engineering Debugging

Due to the precision requirements of engineering design, installation and system control, debugging shall be arranged after finishing engineering installation. The unit can be put into operation after debugging is passed.

4.3 Engineering Debugging

Control the operation of water heater with wired controller. Check the following items according to the instruction manual: (if there is malfunction, please arrange trouble shooting according to the error code table and causes)

- (1) If the switch of wired controller works normally.
- (2) If each function button works normally.
- (3) If the indicator of main board is on.
- (4) Press the electric heating operation button and see if the button works normally.
- (5) If the drainage is smooth.
- (6) Check if the unit works normally under water heating mode.
- (7) If the water outlet temperature and the difference between water inlet and outlet temperature is ok.
- (8) If there is vibration and abnormal sound during operation.
- (9) If the air, noise and condensation water generated may affect neighbourhood.
- (10) If there is refrigerant leakage.

Cold water lifting pump drains out and cold water pipe drains out

Circulating pump drains out and circulating pipe drains out

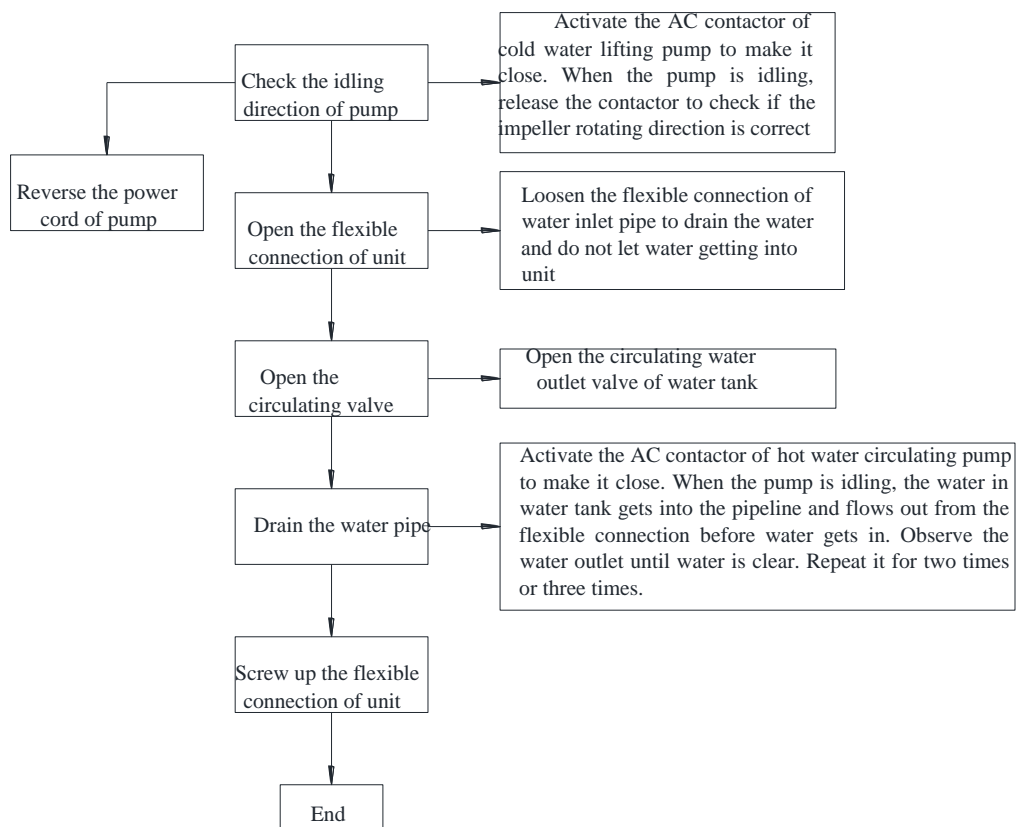

4.4 Finish Debugging Operation

Record the unit operation parameters

Debugging operation parameters

Engineering project name		Unit model	
Debugging personnel		Debugging date	
Rated capacity of outdoor unit(kW)		Capacity of water tank	
Max difference between ODU and water tank(m)		Lift of pump	
Debugging status: <input type="checkbox"/> water heating			
Status parameters		Unit	Before turning on the unit
ODU status parameters	Outdoor ambient temperature	°C	60min
	Power supply voltage	V	
	Suction temperature	°C	
	Discharge temperature	°C	
Water tank parameters	Temperature of water outlet pipe temperature sensor	°C	
	Temperature of water tank temperature sensor	°C	
Debugging conclusion			

4.5 Unit Normal Operation Parameters Judgment Reference

(Debugging Detection)

During operation, as the difference between water temperature and ambient temperature, the suction temperature, discharge temperature and compressor current may vary. When ambient temperature rises, suction temperature and compressor current will increase. When water temperature increases, discharge temperature and compressor current will increase. Actual

parameters of unit can refer to the parameters of nominal working condition.

Engineering project name				Unit model
Debugging personnel				Date
Rated flow(m ³ /h) and lift(m) of circulating pump			Flow: Lift:	Capacity of water tank(m ³): Choose the model according to the lowest temperature
Circulating water inlet pipe diameter(mm)		Circulating water outlet pipe diameter(mm)		
Debugging status: <input checked="" type="checkbox"/> Circulating		Quantity of modular units:		
Status parameters		Unit	Before turning on the unit	30min
Outdoor ambient temperature is 20℃; water inlet temperature is 15℃; water outlet temperature is set in 50℃	Outdoor ambient temperature	℃		
	Power supply voltage	V		
	Compressor current	A		
	Discharge temperature	℃		
	Suction temperature	℃		
	Water outlet temperature	℃		
Debugging conclusion				

5. Unit Function Settings



Note:

- This instruction is only applicable for the main board of water heater.
- Please ask professional person to operate the DIP.
- Cut off the power before operating the DIP.

There are two groups of DIP for the main board of water heater. The first SA3 (4-bit DIP) group is the address DIP for the unit, which is set 1# unit during ex-factory and can be operated by professional debugging person. The other group SA5 (2-bit) is the parameters DIP, which is set well at ex-factory.

DIP address setting will be stated as below by two kinds of circumstances:

- ◆ Single unit

If the system is constituted by one set of unit, the professional debugging person only have to check and confirm whether the DIP is 1# because the address DIP is set at 1# unit at ex-factory. Therefore, it's no need to operate this DIP.

◆Module unit

If the modular system is constituted by multiple units, the address Dip should be operate by the professional debugging person during installation.

In module system, you must appoint one unit as the 1# unit, and the other units are 2#、3#...16# in turn.

Because all the units are the same, you can appointed the most convenient unit in the project as the 1# unit.

Address DIP of unit: (black part is the deflector rod)

DIP	Position				Address	Instruction
	1	2	3	4		
SA3	ON	ON	ON	ON	1#	ON: pull the deflector rod to the direction of ON; the opposite direction is OFF.
	OFF	ON	ON	ON	2#	
	ON	OFF	ON	ON	3#	
	OFF	OFF	ON	ON	4#	
	ON	ON	OFF	ON	5#	
	OFF	ON	OFF	ON	6#	
	ON	OFF	OFF	ON	7#	
	OFF	OFF	OFF	ON	8#	
	ON	ON	ON	OFF	9#	
	OFF	ON	ON	OFF	10#	
	ON	OFF	ON	OFF	11#	
	OFF	OFF	ON	OFF	12#	
	ON	ON	OFF	OFF	13#	
	OFF	ON	OFF	OFF	14#	
	ON	OFF	OFF	OFF	15#	
	OFF	OFF	OFF	OFF	16#	

Address DIP diagram:

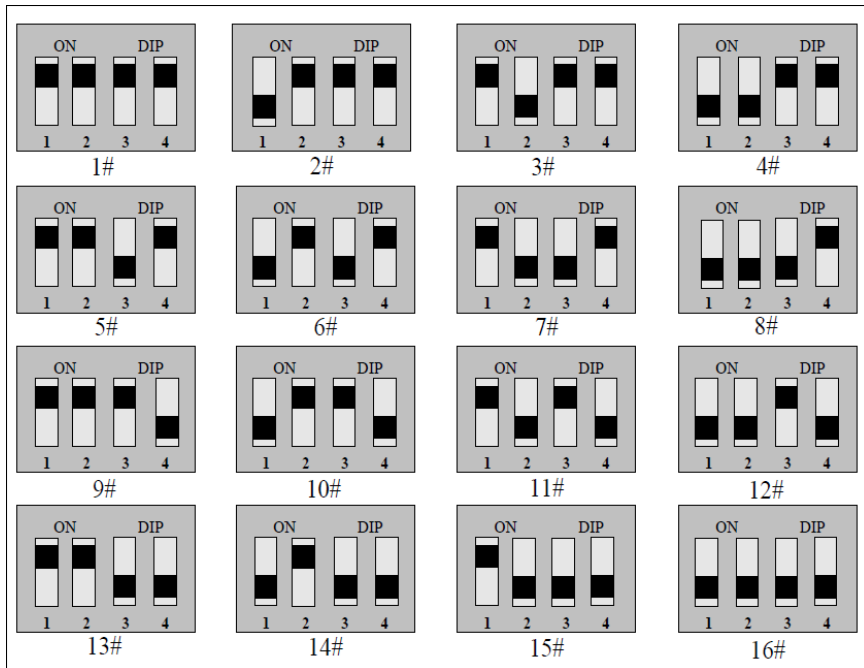

Chapter IV Maintenance

1. Error Code

Error code	Error name	Source of error signal	Control logic
E1	High pressure protection	High pressure switch	The high pressure switch is used to detect the high pressure of system and protect the unit from operating in an abnormal status. When the high pressure of the system exceeds the set value, the corresponding compressor will be shut down immediately. 15 sec later, the fan will be shut down and the error code will be displayed. Operation cannot be restored automatically. If the error is eliminated after you press the "reset" button, error is cleared.
E3	Low pressure protection	Low pressure switch	Low pressure switch is used to detect the low pressure of the system and protect the unit from operating in an abnormal status. When the low pressure of the system is lower than the set value, the compressor and the fan will be shut down in turn. If the switch is recovered after 3 min, operation will be restored automatically. If low pressure protection is detected twice within 40 min, the error code will be displayed and operation cannot be automatically restored. If the error is eliminated after you press the "reset" button, error is cleared.
E4	High discharge temperature protection	Discharge temperature sensor	The discharge temperature sensor is used to prevent unit failure or damage arising from compressor oil decomposition and carbonization when system is operating in an abnormal status and discharge temperature is too high. If the discharge temperature is higher than the set value (130°C) of discharge temperature protection or the discharge temperature sensor is disconnected, the corresponding compressor will be shut down. If the error is eliminated after you press the "reset" button, error is cleared.
E5	Compressor overload protection	Compressor overload protector	Compressor overload protection aims to protect the compressor as regards operation safety. It prevents damage to the compressor arising from over-high discharge temperature or high-pressure ratio. In case of compressor overload protection, compressor and fan will be shut down accordingly. If the switch is recovered after 3 min, operation will be restored automatically. If compressor overload protection is detected for 3 times within 30 min, the error code will be displayed and system cannot restore operation. If the error is eliminated after you press the "reset" button, error is cleared.
E6	Communication error	Wired controller signal cable	When units are connected, one of the units must be set as unit 1. If the wired controller cannot detect unit 1 in 1 min, the error code will be displayed. After unit 1 is correctly connected, error code will disappear and communication is normal.

Chapter IV Maintenance (1. Error Code)

Ec	Water flow switch protection	Water flow switch	Water flow switch protection aims to prevent over-high fluorine system pressure of the unit arising from over-low entering water pressure or poor water flow. When disconnection of the water flow switch is detected during operation, unit will stop and the water makeup valve will be closed. Waterway pressure switch can be reset automatically. When the startup conditions are satisfied, unit will start up automatically and each component is controlled normally. If the error is eliminated after you press the “reset” button, error is cleared.
Ed	System high temperature protection	Leaving water temperature	If the leaving water temperature is higher than 65℃ when compressor is operating, turn off all the loads immediately. When the leaving water temperature drops lower than 60℃, high temperature protection is cancelled and unit will operate according to the original operating condition of water heating.
F3	Outdoor ambient temperature sensor error	Outdoor ambient temperature sensor	Outdoor ambient temperature sensor is one condition used to control whether unit can enter the defrosting status and the condition of starting up the unit. If outdoor ambient temperature sensor detects open circuit or short circuit, the error code is displayed and all the loads are shut down. After system is recovered automatically, unit restores operation.
F4	Discharge temperature sensor error	Discharge temperature sensor	The discharge temperature sensor is used to prevent unit failure or damage arising from compressor oil decomposition and carbonization when system is operating in an abnormal status and discharge temperature is too high. When open circuit or short circuit occurs to the discharge temperature sensor, unit will display the error code and the corresponding load is shut down. After system is recovered automatically, unit restores operation.
F5	Outdoor inlet pipe temperature sensor error	Outdoor inlet pipe temperature sensor	In order to implement defrosting timely when the unit is operating in winter, the outdoor inlet pipe temperature sensor is one of the conditions used to detect whether unit can enter the defrosting status. When open circuit or short circuit occurs to the outdoor inlet pipe temperature sensor, the error code is displayed and all the loads are shut down. After system is recovered automatically, unit restores operation.
F7	Outdoor outlet pipe temperature sensor error	Outdoor outlet pipe temperature sensor	Error of the outdoor outlet pipe temperature sensor is one of the conditions used to judge whether unit can exit the defrosting status. When open circuit or short circuit occurs to the outdoor outlet pipe temperature sensor, the error code is displayed and all the loads are shut down. After system is recovered automatically, unit restores operation.
F8	Entering water temperature sensor error	Entering water temperature sensor	When the entering water temperature sensor fails to work, unit will still operate but error code is displayed. The error is cleared automatically when it is recovered.
F9	Leaving water temperature sensor error	Leaving water temperature sensor	When the leaving water temperature sensor fails to work, unit will still operate but error code is displayed. The error is cleared automatically when it is recovered.

Chapter IV Maintenance (1. Error Code)

L2	Water level switch error of the water tank	Water level switch	When the high-level water level switch indicates that water level is high and the low-level water level switch indicates that water level is low, the unit reports the water level switch error. If the error setting is absent, unit will start or stop abnormally. If the error is eliminated, unit can restore operation automatically.
L5	Water tank temperature sensor error	Water tank temperature sensor	When open circuit or short circuit occurs to the water tank temperature sensor (water supply outlet from water tank to the unit), the error code is displayed and all the loads are shut down. After system is recovered automatically, unit restores operation.
d3	Error on sensor of anti-freezing for shell and tube	Sensor of anti-freezing for shell and tube	Sensor of anti-freezing for shell and tube is used for detecting the temperature shell and tube. When the sensor occurs error, the unit operates normally and error code is displayed. The error will be cleared automatically when error resumes.
n6	Communication error for electric expanding valve drive board	Electric expanding valve drive board	When the unit is energized and when the drive board hasn't received the communication information of main board for 20s continuously, the drive board will report communication malfunction. When the drive board and main board connect normally, the error will disappear.

2. Troubleshooting

2.1 System Troubleshooting

2.1.1 High pressure protection

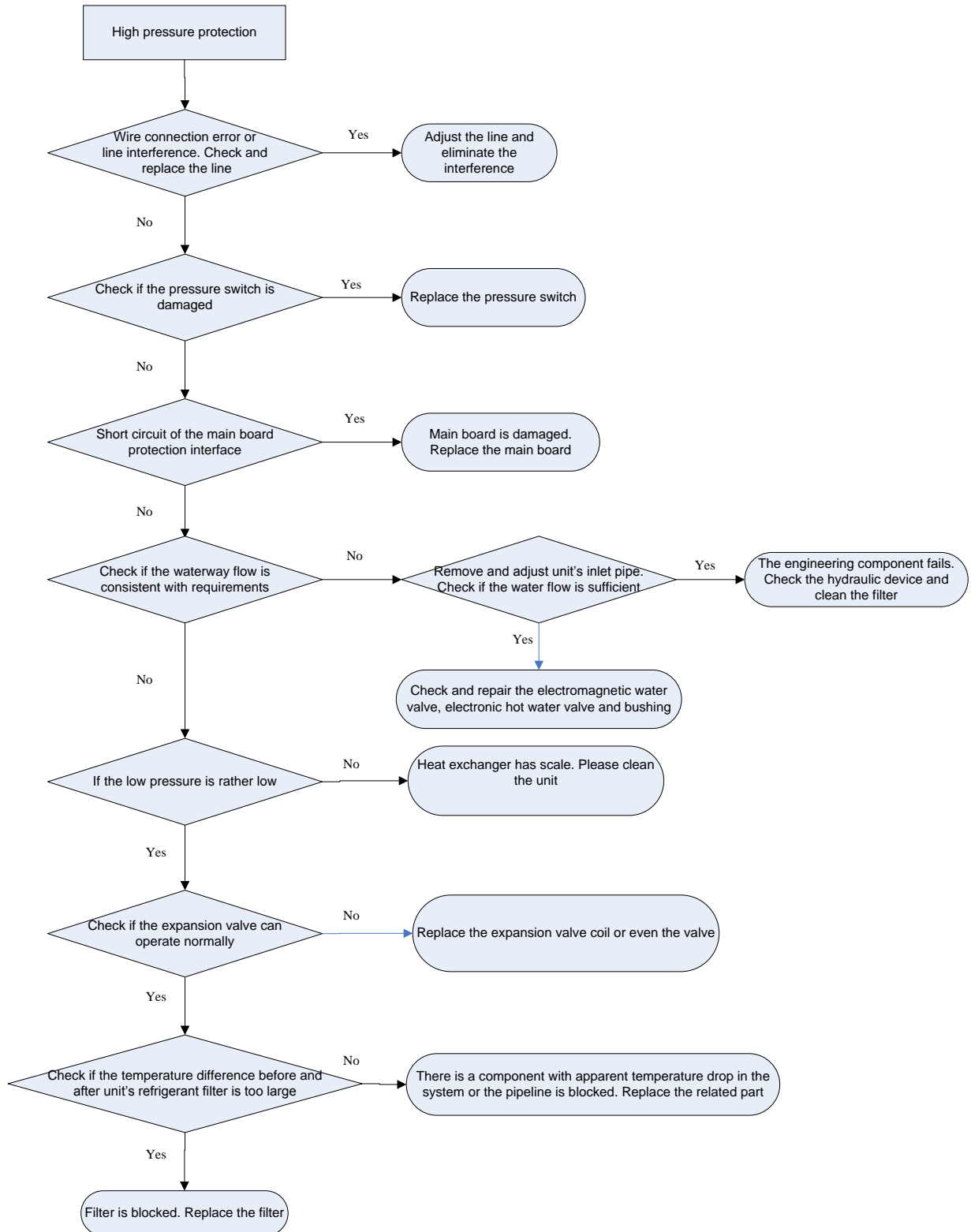

2.1.2 Low pressure protection

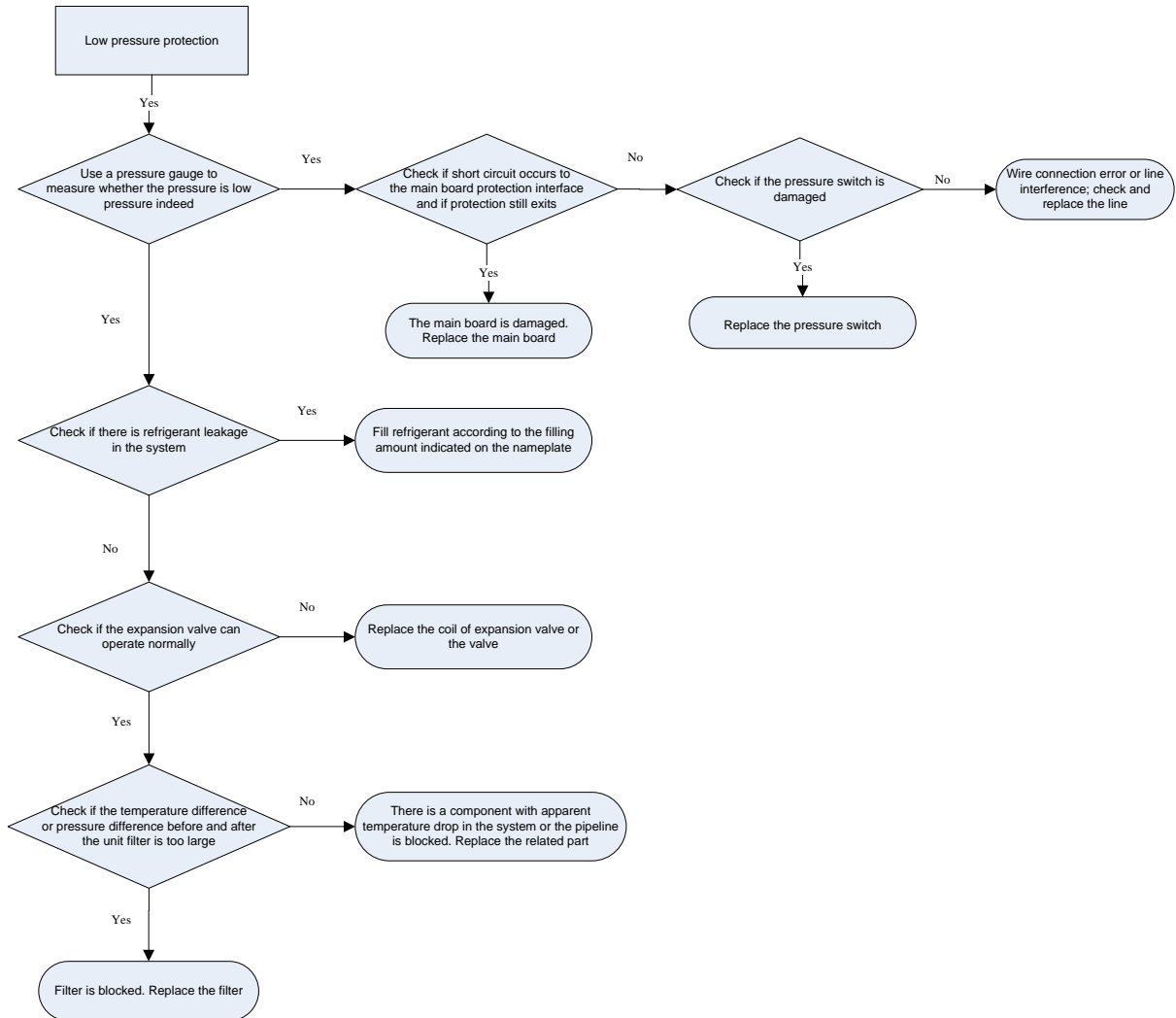

2.1.3 High discharge temperature protection

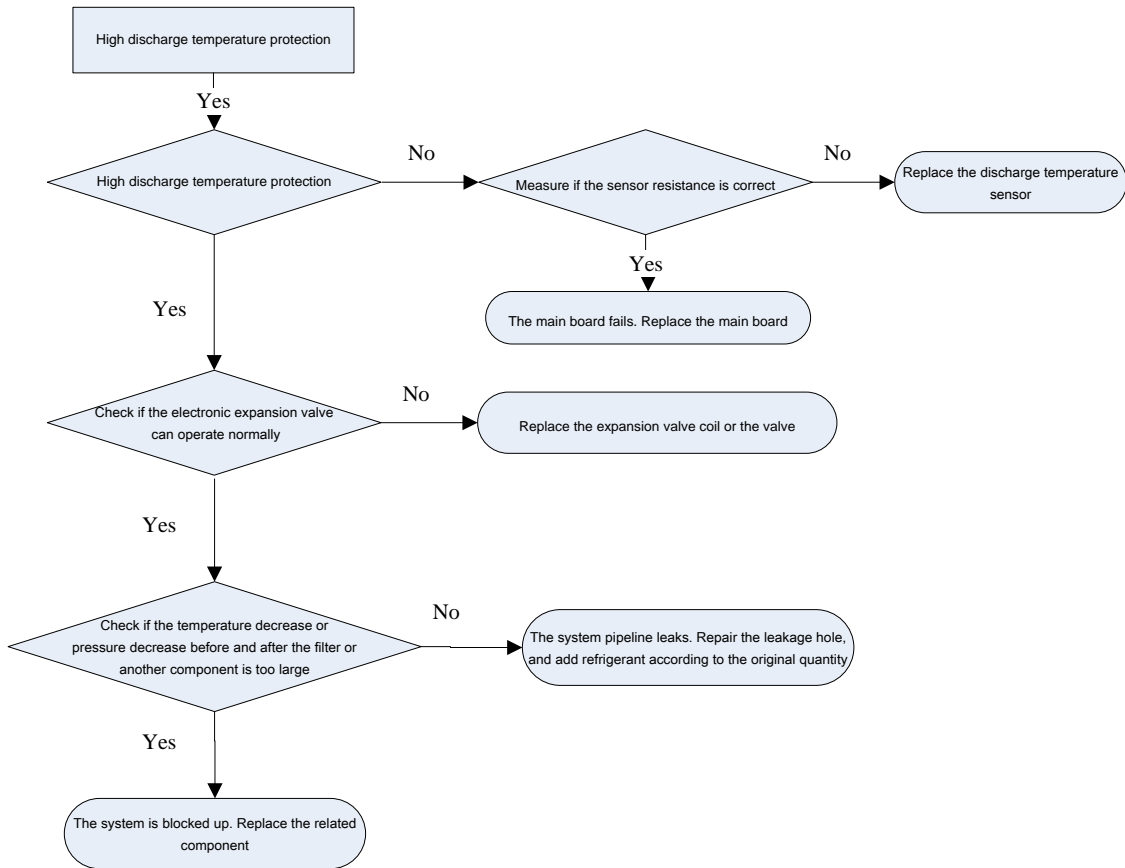

2.1.4 Water level switch error of the unit

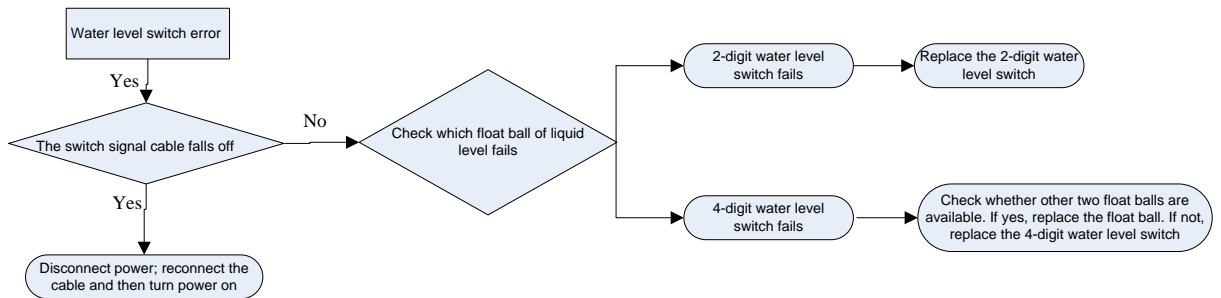

2.1.5 Water flow switch protection

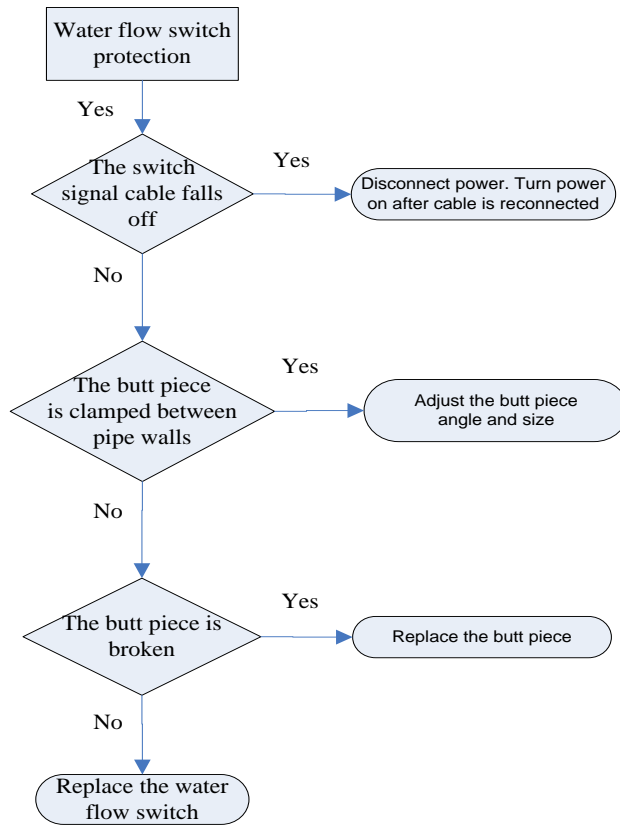

2.1.6 Communication error

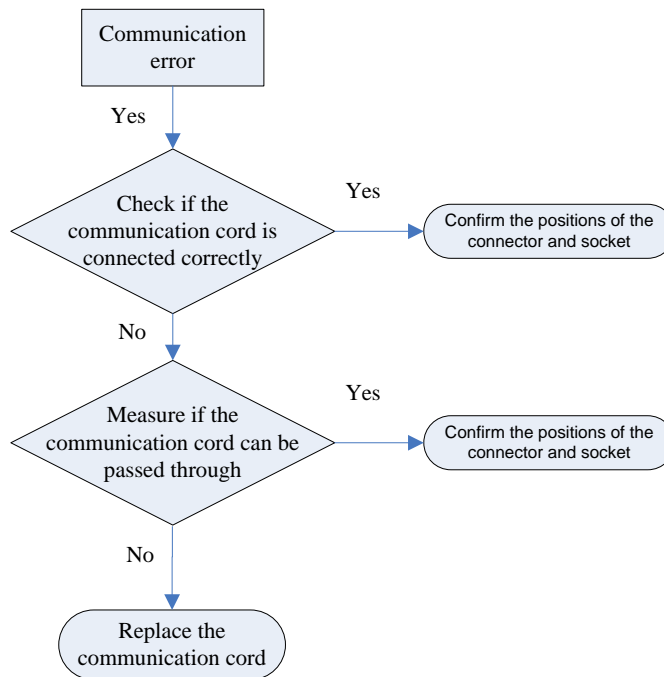

2.1.7 Temperature sensor error

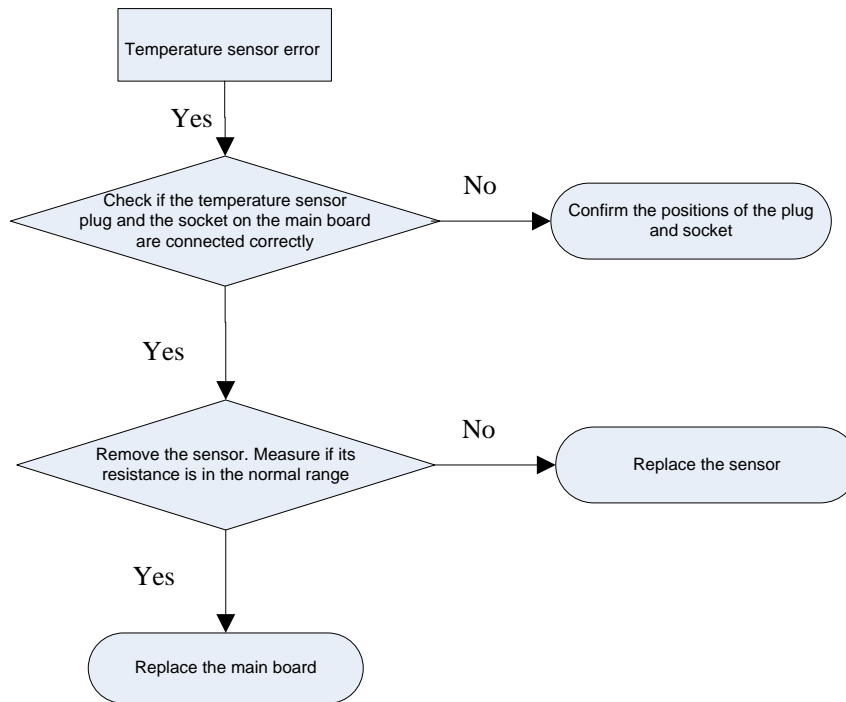

2.2 Controller Troubleshooting

2.2.1 Fault of display board

◆ Phenomenon: Display board is not lighted up after powering on.

◆ Possible causes: ① Display board malfunctions; ② The line is wrongly connected.

◆ Troubleshooting: First check whether the main board is powered on. If condition permits, use a multimeter to test whether each power module can operate normally. Alternatively, you can just check whether the digital tube of the main board is displayed normally. Normally, the 2-digit digital tube should display "00" or an error code. You can also check whether the communication indicator is lighted up. After making sure that main board is powered on, check whether the communication cable of display panel is connected correctly. If yes, you can judge that the display panel is damaged. Replace the display panel.

2.2.2 Fault of main board

◆ Phenomenon: The main board does not work after powering on.

◆ Possible causes: ① Main board malfunctions; ② The line is wrongly connected.

◆ Troubleshooting:

① check if there is any err code display on display board or the double 8 digital displayer on

the main board. If yes, go check the err code.

② Powered on the machine. Use a voltage meter to test the power supply check point as the figure below shows, the voltage should be 187V~264V, If there is no power, check whether the power supply connection of the main board is correct.

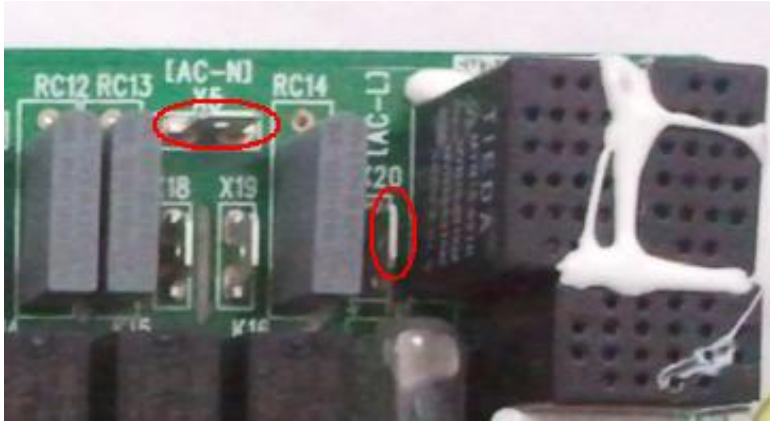

① Check the fuse which you can locate as the figure below. Replace the fuse if it failed



④ If nothing wrong with the power supply, check whether the double 8 digital displayer on the main board is displayed normally. Normally, the 2-digit digital tube should display “00” or an error code. You can also check whether the communication indicator is flashing. It could be malfunction of the main board if the double 8 digital displayer does not display anything and the communication indicator is not flashing. Replace the main board

2.3 Other Common Errors and Their Causes

Error phenomenon	Causes	Troubleshooting
Compressor can't be started up	A、 There's problem for the power B、 Wire connection is loose C、 Malfunction of relay or fuse D、 Malfunction of compressor	<ul style="list-style-type: none"> ●Check the phase sequence. ●Check it and connect it tightly. ●Check the malfunction cause and resolve it. ●Replace compressor.
Big noise for fan	A、 The fixing bolt for the fan is loose B、 Blades touch outer case or grille C、 The fan can't operate placidly	<ul style="list-style-type: none"> ●Tighten the fixing bolts of fan. ●Check it and adjust it. ●Replace the fan.
Big noise for the compressor	A、 There's liquid slugging when liquid refrigerant entering into compressor B、 There's damaged part inside the compressor	<ul style="list-style-type: none"> ●Check whether the expansion valve is valid and whether the temperature is loose. ●Replace compressor.
Water pump can't operate or the operation is abnormal	A、 Power malfunction of wiring malfunction B、 Malfunction of relay C、 There's air inside the water pipe	<ul style="list-style-type: none"> ●Find out the reason and repair it. ●Replace relay. ●Discharge the air completely.
Compressor is turned on or turned off frequently	A、 Refrigerant is superfluous or too less B、 Poor circulation for the water system C、 Low load	<ul style="list-style-type: none"> ●Add or release some refrigerant. ●The water system is blocked or there's air inside the water system. Please check water pump, valve and pipeline, clean the strainer or discharge air. ●Adjust the load or add energy-storage device.
Compressor operates, while the unit can't heat	A、 Refrigerant is leaked B、 Malfunction of compressor	<ul style="list-style-type: none"> ●Repair it and complement refrigerant. ●Replace compressor.
The hot water generation effect is not obvious	A、 The thermal insulation for the water system is poor B、 The heat-exchanging effect for the evaporator is poor C、 Refrigerant is insufficient D、 Water side heater exchanger is blocked	<ul style="list-style-type: none"> ●Enforce the thermal insulation for the system. ●Check whether air inlet and air outlet for the unit is normal and clean the evaporator. ●Check whether there's refrigerant leakage for the unit. ●Clean or replace the heat exchanger.



Note: The phenomena in the following table are not errors.

Phenomenon(not error)	Cause
Temperature of the leaving water fluctuates	Due to difference of the entering water pressure, the leaving water temperature may fluctuate in special working conditions. It is normal and does not affect actual use. You can adjust the water pressure properly to improve the phenomenon.
Leaving water temperature of low temperature fails to reach the set temperature.	In the low temperature condition, the leaving water temperature may fail to reach the set higher temperature for the purpose of unit protection. It is normal and does not affect normal use.

3. Maintenance of Key Parts

3.1 Introduction of Key Parts

Picture	Name	Function
	Compressor	<p>It uses electricity as the driving power to compress refrigerant into high temperature and high pressure gas and makes it overcome resistance in the cooling system to flow circularly and constantly.</p>
	Gas-liquid separator	<p>It is used to separate gas refrigerant and liquid refrigerant. It can prevent the compressor from taking in liquid refrigerant and therefore prevent liquid impact. The gas-liquid separator is located at the suction port of the compressor.</p>
	Tube in tube heat exchanger	<p>The high pressure and high temperature gas discharged from the compressor releases heat inside the tube in tube heat exchanger and heat up the water.</p>
	Electronic expansion valve	<p>Firstly, it throttles and reduces pressure of the high pressure liquid refrigerant to ensure the pressure difference between the condenser and the evaporator.</p> <p>Secondly, it adjusts the refrigerant flow in the evaporator to adapt to the heat load change of evaporator so that the cooling device can operate stably.</p>

	<p>4-way valve</p>	<p>It is a device used to change the direction of refrigerant flow when the circulating type water heater is in defrosting status. After entering the defrosting status, refrigerant is compressed by the compressor. Meanwhile, the 4-way valve takes action and the refrigerant direction will be changed. It will enter the evaporator directly for heat exchange and defrosting. Then it will flow into the tube in tube heat exchanger via the expansion valve. After that, refrigerant is sucked back by the compressor and repeats its flow again.</p>
	<p>Water flow switch</p>	<p>It is used to control the water flow in the water system and prevent frequent abnormality protection of the unit due to large/poor flow.</p>

3.2 Removal/Installation of Key Parts

3.2.1 Removal/Installation of GRS-Cm28/NaA-M、GRS-Cm28/NaA1-M main unit

3.2.1.1 Compressor

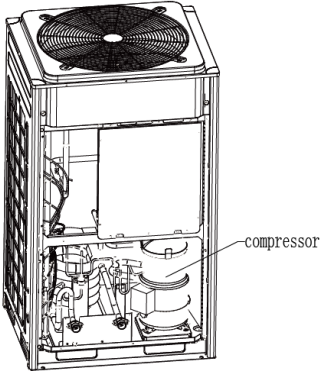
<p>Removal/ Installation of the compressor</p>		
<p>Remarks: Before removing the compressor, make sure there is no refrigerant in unit's pipeline system and power supply is cut off.</p>		
Step	Figure	Operation Instructions
<p>1、Remove the front panel, compressor power cable and the electric heating band.</p>		<ul style="list-style-type: none"> ● First use a screwdriver to remove the front panel; ● Use a screwdriver to loosen the power cord fixing screw; ● Then take away compressor's power cord and remove the electric heating band; ● Reclaim the refrigerant.

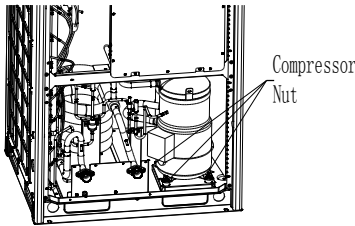
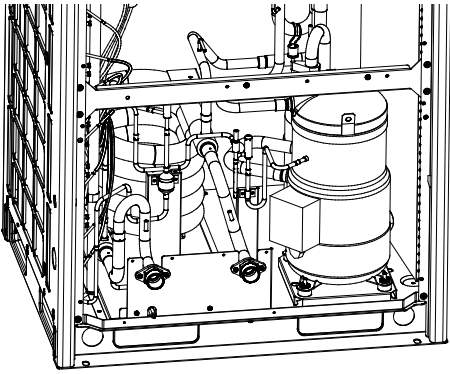
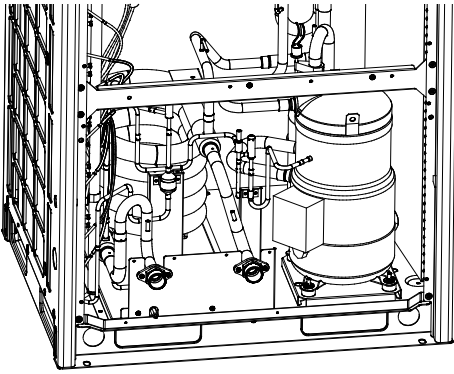
<p>2 、 Remove the nuts fixing the compressor footing.</p>		<ul style="list-style-type: none"> ● Use bending bar or other tools to unfasten the compressor fixing nuts.
<p>3、 Cut off the pipes from the compressor.</p>		<ul style="list-style-type: none"> ● When using a soldering gun, weld the pipes quickly to prevent pipeline from overburning; ● In order to guarantee compressor replacement and for future disassembly analysis, do not damage the
<p>4 、 Remove the compressor from the base plate and locate a new compressor onto the baseplate.</p>		<ul style="list-style-type: none"> ● When removing the compressor, be careful not to damage compressor's rubber grommet; ● The replaced compressor should be well sealed to prevent water from getting in; ● Place the newly replaced compressor onto the rubber grommets. Wear steel bushing on the center of the grommet; ● Tighten up the nuts to the position of steel bushing.
<p>5 、 Connect the suction port and discharge port of compressor to the system pipeline. Connect power cord and check whether the compressor can run normally.</p>		<ul style="list-style-type: none"> ● Connect the suction and discharge pipeline to the compressor by welding. Fill nitrogen for the welding; ● After welding, it is required to fill high pressure nitrogen to conduct leak test; ● Power on the unit and energize the AC contactor of the compressor manually to turn compressor on for 2~3 seconds; ● If compressor is reversed, ear-piercing noise will occur.

<p>6 、 Retain system pressure, vacuumize and recharge refrigerant.</p>	<p>—</p>	<ul style="list-style-type: none"> • Detect system leakage; • Make sure the vacuum degree reaches -1.0bar; • Type and amount of refrigerant should accord with requirements on unit's nameplate.
--	----------	---

3.2.1.2 Gas-liquid separator

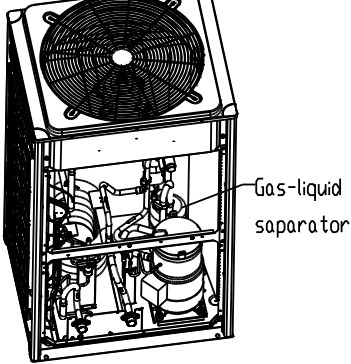
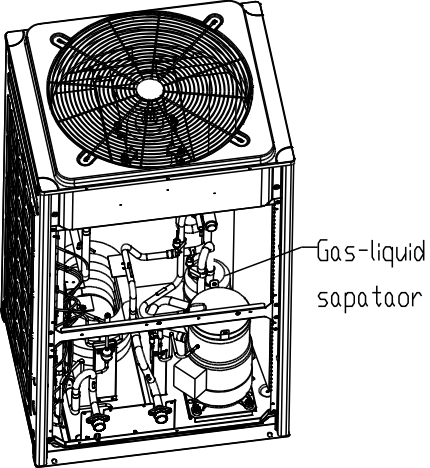
<p>Removal/ Installation of the gas-liquid separator and liquid storage tank.</p>		
<p>Remarks: Reclaim refrigerant properly. Prepare related devices and tools. Make sure power is off.</p>		
Step	Figure	Operation Instructions
<p>1、 Reclaim the refrigerant and then remove the gas-liquid separator. Take off the nuts and bolts on the base plate.</p>		<ul style="list-style-type: none"> • Reclaim the refrigerant; • Disassemble the connection pipes by welding; • Use spanner or other tools to take off the fixing nuts and bolts. Remove the gas-liquid separator.
<p>2 、 Clean the system accordingly. Replace with a same model gas-liquid separator.</p>		<ul style="list-style-type: none"> • Replace with a same model gas-liquid separator and secure it with nuts and bolts; • Then connect the pipes with gas-liquid separator.

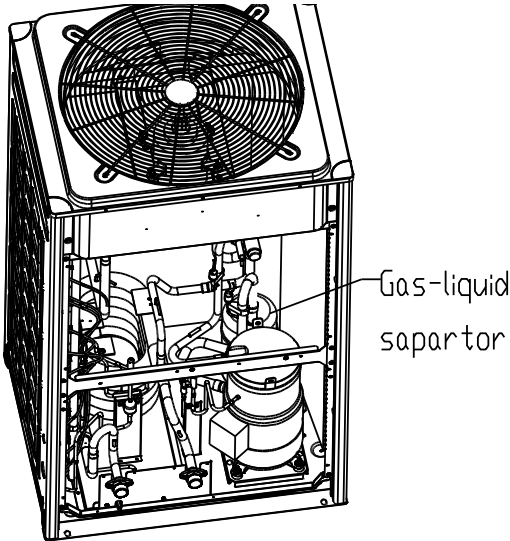
<p>3 、 Assemble and weld the connection pipe of gas-liquid separator. Add nitrogen during welding for protection.</p>		<ul style="list-style-type: none"> ● Use soldering gun to weld the pipes; ● Note: Add nitrogen when welding.
<p>4 、 Retain system pressure, vacuumize and recharge refrigerant.</p>		<ul style="list-style-type: none"> ● Detect system leakage; ● Make sure the vacuum degree reaches -1.0bar; ● Type and amount of refrigerant should accord with requirements on unit's nameplate.

3.2.1.3 Tube in tube heat exchanger

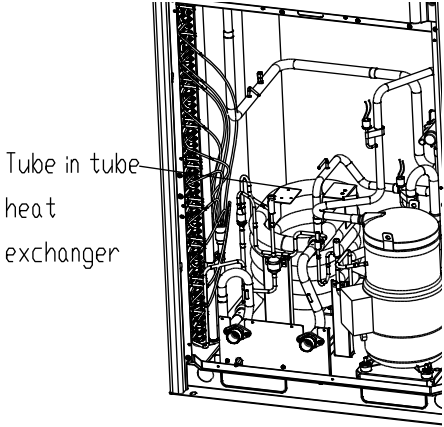
<p>Removal/ Installation of tube in tube condenser</p>		
<p>Remarks: Check the refrigerant system and each circuit. After making sure that it is necessary to replace the tube in tube condenser, disconnect power and reclaim the refrigerant.</p>		
Step	Figure	Operation Instructions
<p>1 、 Reclaim the refrigerant and remove the fluorine connection pipe and waterway connection pipe of the tube in tube heat exchanger.</p>		<ul style="list-style-type: none"> ● Disconnect power of the unit; ● Retrieve the refrigerant; ● Disconnect the fluorine connection pipe by using the soldering gun. Twist off the waterway connection pipe.

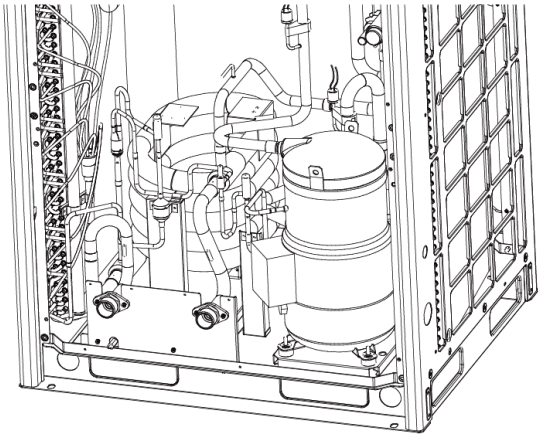
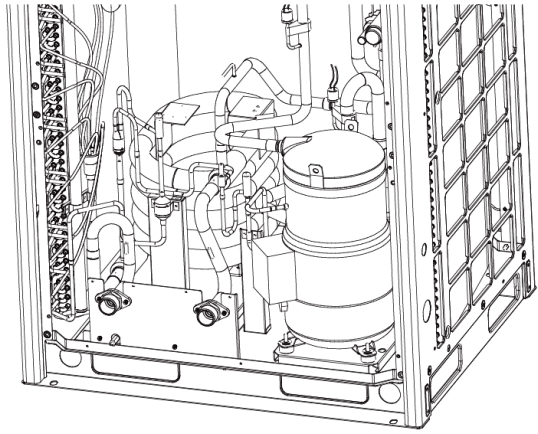
<p>2、Take off the fixing nuts of tube in tube condenser and then remove the tube in tube condenser.</p>		<ul style="list-style-type: none"> ● Take off the fixing nuts by using a spanner or other tools; ● Remove the tube in tube condenser from the base plate.
<p>3、Replace with a new tube in tube condenser and then secure the nuts.</p>		<ul style="list-style-type: none"> ● Install the new tube in tube condenser on the base plate; ● Use a spanner to tighten up the fixing nuts of tube in tube condenser; ● Weld the fluorine connection pipe and tighten the waterway connection pipe.
<p>4、Reclaim system pressure, vacuumize and recharge refrigerant.</p>	<p>—</p>	<ul style="list-style-type: none"> ● Detect system leakage; ● Make sure the vacuum degree reaches -1.0bar; ● Type and amount of refrigerant should accord with requirements on unit's nameplate.

3.2.1.4 Electronic expansion valve

<p>Removal/ Installation of electronic expansion valve</p>		
<p>Remarks: Check the refrigerant system and each circuit. After making sure that it is necessary to replace electronic expansion valve, disconnect power and reclaim the refrigerant.</p>		
<p>Step</p>	<p>Figure</p>	<p>Operation Instructions</p>

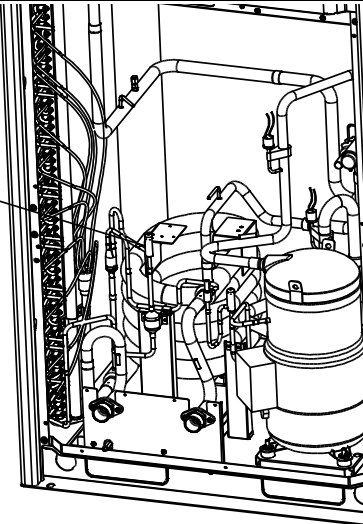
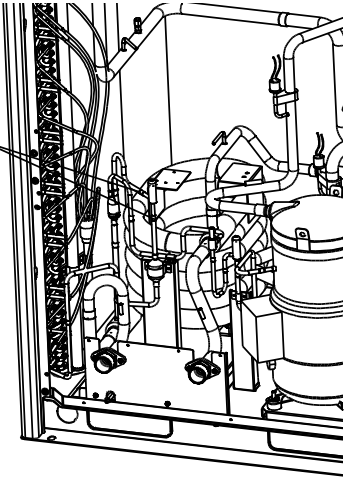
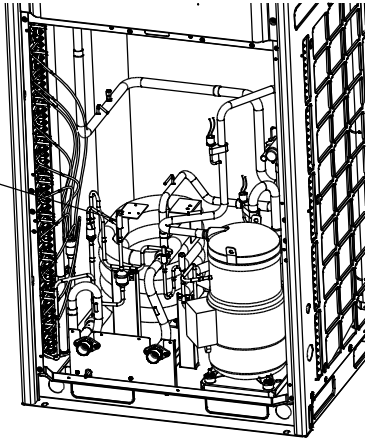
<p>1、Reclaim the refrigerant.</p>	 <p>Electronic expansion valve</p>	<ul style="list-style-type: none"> ● Disconnect power of the unit; ● Reclaim the refrigerant.
<p>2、Remove the electronic expansion valve</p>	 <p>Welding point</p>	<ul style="list-style-type: none"> ● In order to protect the EXV, wrap it with wet cloth during welding; ● Remove the EXV by using the soldering gun.
<p>3、Replace with a new electronic expansion valve.</p>	 <p>Electronic expansion valve</p>	<ul style="list-style-type: none"> ● Replace with a new EXV that is of the same model; ● Wrap the EXV with wet cloth and mount it on. Connect the connection pipe; ● Weld it with soldering gun; ● Note: Add nitrogen into the pipe when welding.
<p>4、Retain system pressure, vacuumize and recharge refrigerant.</p>	<p>—</p>	<ul style="list-style-type: none"> ● Detect system leakage; ● Make sure the vacuum degree reaches -1.0bar; ● Type and amount of refrigerant should accord with requirements on unit's nameplate.

3.2.1.5 4-way valve

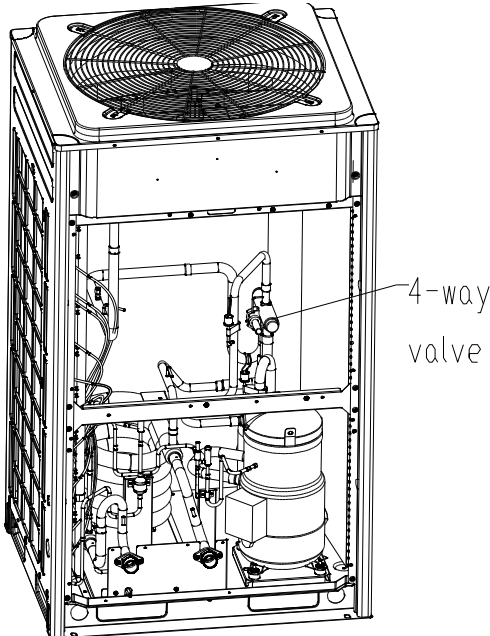
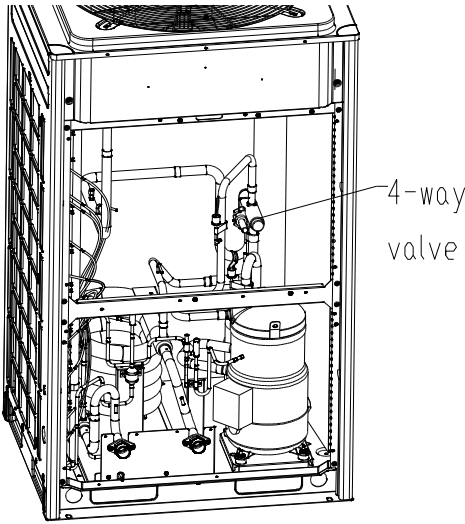
Removal/ Installation of 4-way valve		
Remarks: Before replacing, cut off the power and reclaim refrigerant.		
Step	Figure	Operation Instructions
1、 Reclaim the refrigerant. Before removing the valve, record its direction. Even for a dual-system, do not refer to the other system for valve direction.		<ul style="list-style-type: none"> ● Reclaim the refrigerant; ● Before removing the 4-way valve, please remember the installed direction of the valve; ● Remove the coil; ● In order to guarantee the integrity of 4-way valve and for future disassembly analysis, wrap the 4-way valve with wet cloth before welding; ● Remove the 4-way valve by welding.
2、 Clean the system accordingly. Replace the 4-way valve with the same model. Pipe connection should also be consistent with the original connection of 4-way valve.		<ul style="list-style-type: none"> ● In principle, model of the new valve should be the same as the replaced one. In special cases where same model cannot be guaranteed, please ask professional technicians for confirmation; ● Wrap the 4-way valve with wet cloth; ● Connect the valve with the 4 pipes according to the original direction of valve coil; ● Weld the pipes with soldering gun; ● Remember to charge nitrogen when welding.
3、 Retain system pressure, vacuumize and recharge refrigerant.	—	<ul style="list-style-type: none"> ● Detect system leakage; ● Make sure the vacuum degree reaches -1.0bar; ● Type and amount of refrigerant should accord with requirements on unit's nameplate.

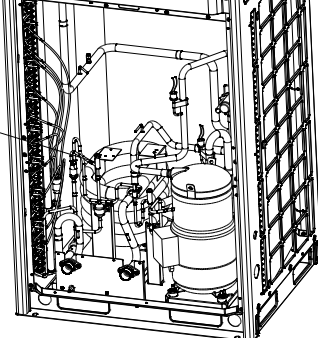
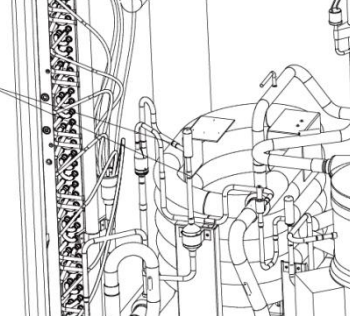
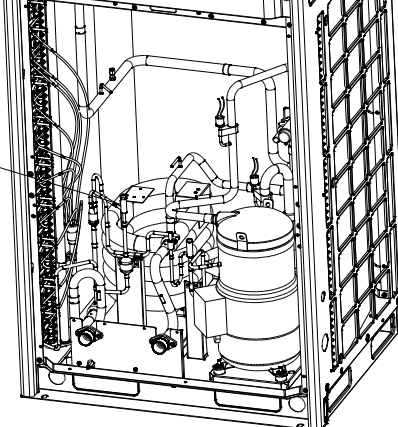
Removal/ Installation of electronic expansion valve		
Remarks: Check the refrigerant system and each circuit. After making sure that it is necessary to replace electronic expansion valve, disconnect power and reclaim the refrigerant.		
Step	Figure	Operation Instructions
1、 Reclaim the refrigerant.		<ul style="list-style-type: none"> ● Disconnect power of the unit; ● Reclaim the refrigerant.
2、 Remove the electronic expansion valve.		<ul style="list-style-type: none"> ● In order to protect the EXV, wrap it with wet cloth during welding; ● Remove the EXV by using the soldering gun.
3、 Replace with a new electronic expansion valve.		<ul style="list-style-type: none"> ● Replace with a new EXV that is of the same model; ● Wrap the EXV with wet cloth and mount it on. Connect the connection pipe; ● Weld it with soldering gun; ● Note: Add nitrogen into the pipe when welding.
4、 Retain system pressure, vacuumize and recharge refrigerant.	—	<ul style="list-style-type: none"> ● Detect system leakage; ● Make sure the vacuum degree reaches -1.0bar; ● Type and amount of refrigerant should accord with requirements on unit's nameplate.

3.2.1.6 Strainer

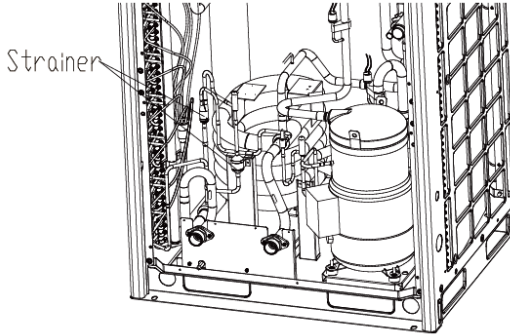
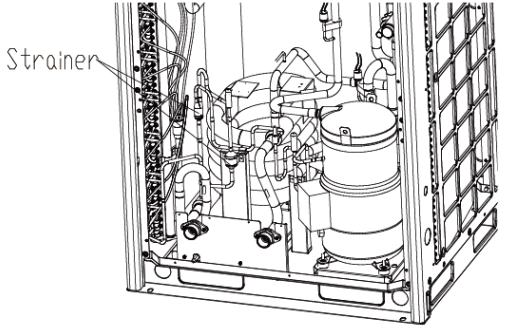
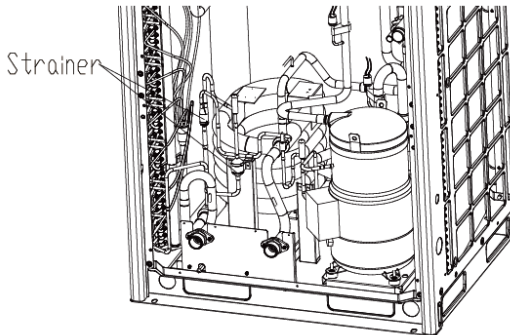
Removal/ Installation of strainer		
Remarks: Check the refrigerant system and each circuit. After making sure that it is necessary to replace the filter, disconnect power and reclaim the refrigerant.		
Step	Figure	Operation Instructions
1、 Reclaim the refrigerant.		<ul style="list-style-type: none"> ● Disconnect power of the unit; ● Reclaim the refrigerant.
2、 Remove the strainer.		<ul style="list-style-type: none"> ● In order to protect the EXV, wrap it with wet cloth during welding; ● Remove the filter by using the soldering gun.
3、 Replace with a new filter.		<ul style="list-style-type: none"> ● Replace with a new filter that is of the same model; ● Wrap the EXV with wet cloth and mount the filter on. Connect the connection pipe; ● Weld it with soldering gun; ● Note: Add nitrogen into the pipe when welding.
4、 Retain system pressure, vacuumize and recharge refrigerant.	—	<ul style="list-style-type: none"> ● Detect system leakage; ● Make sure the vacuum degree reaches -1.0bar; ● Type and amount of refrigerant should accord with requirements on unit's nameplate.

3.2.2 Removal/Installation of GRS-Cm36/NaA-M、GRS-Cm36/NaA1-M main unit

3.2.2.1 Compressor

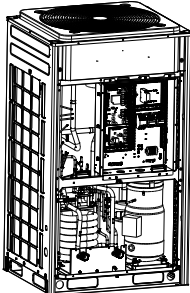
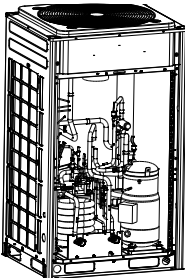
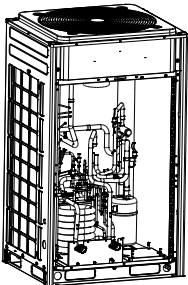
Removal/ Installation of the compressor		
Remarks: Before removing the compressor, make sure there is no refrigerant in unit's pipeline system and power supply is cut off.		
Step	Figure	Operation Instructions
1、Remove the upper part and lower part of the front panel.		<ul style="list-style-type: none"> • Use a screwdriver to detact the upper part and lower part of the front panel.
2、Remove unit's electric box, middle beam, and the power cord of compressor. Reclaim the refrigerant.		<ul style="list-style-type: none"> • Use screw wrench or other tools to remove the electric box and middle beam; • Reclaim the refrigerant.
3、Disconnect compressore from its connection pipe by welding. Screw off the fixing nuts of compressor and remove the compressor.		<ul style="list-style-type: none"> • When using a soldering gun, weld the pipes quickly to prevent pipeline from overburning; • In order to guarantee the integrity of compressor and for furture disassembly analysis, do not damage the compressor; • When removing the compressor, be careful not to damage compressor's rubber grommet; • The replaced compressor should be well sealed to prevent water from getting in.

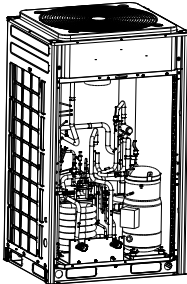
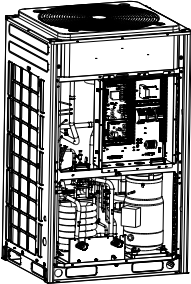
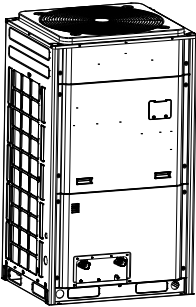
<p>4、 Secure the compressor on chassis and weld the suction pipe and discharge pipe.</p>		<ul style="list-style-type: none"> ● Place the newly replaced compressor onto the rubber grommets. Wear steel bushing on the center of the grommet; ● Tighten up the nuts to the position of steel bushing.
<p>5、 Install the middle beam, electric box and connect the compressor wire properly.</p>		<ul style="list-style-type: none"> ● Secure the electric box; ● Connect wires according to the wiring diagram; ● Power on the unit and energize the AC contactor of the compressor manually to turn compressor on for 2~3 sec; ● If compressor is reversed, ear-piercing noise will occur.
<p>6、 Retain system pressure, vacuumize and recharge refrigerant in. After confirming it's OK, install the front panel.</p>		<ul style="list-style-type: none"> ● Detect system leakage; ● Make sure the vacuum degree reaches -1.0bar; ● Type and amount of refrigerant should accord with requirements on unit's nameplate.

3.2.2.2 Gas-liquid separator

<p>Removal/ Installation of gas-liquid separator</p>		
<p>Remarks: Reclaim refrigerant properly. Prepare related devices and tools. Make sure power is off.</p>		
<p>Step</p>	<p>Figure</p>	<p>Operation Instructions</p>

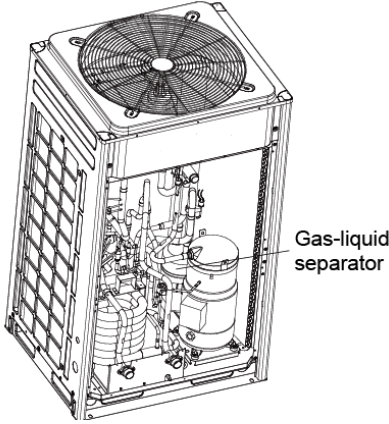
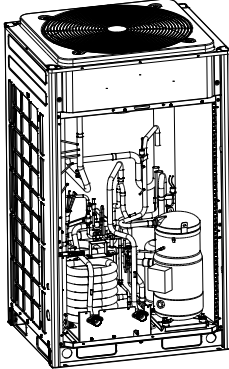
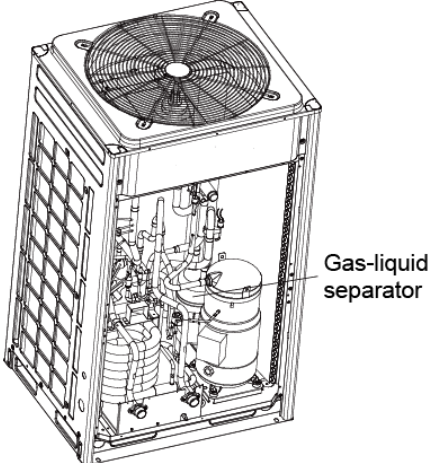
<p>1、 Remove the front panel and electric box according to the previous instructions. Reclaim the refrigerant and then remove the gas-liquid separator and the connection pipe.</p>		<ul style="list-style-type: none"> ● Reclaim the refrigerant; ● Disassemble the connection pipes by welding.
<p>2、Take off the bolts on the base plate of gas-liquid separator.</p>		<ul style="list-style-type: none"> ● Take off the fixing bolts by using a spanner or other tools. Remove the gas-liquid separator.
<p>3、 Assemble and weld the connection pipes of gas-liquid separator. Add nitrogen during welding for protection.</p>		<ul style="list-style-type: none"> ● Install the new gas-liquid separator according to the original direction. Match the pipes correspondingly. Use soldering gun to weld the pipes; ● Note: Add nitrogen when welding.

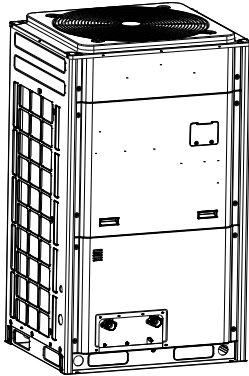
<p>4、 Retain system pressure, vacuumize and recharge refrigerant in. After confirming it's OK, install the middle beam, electric box and the front panel.</p>		<ul style="list-style-type: none"> • Detect system leakage; • Make sure the vacuum degree reaches -1.0bar; • Type and amount of refrigerant should accord with requirements on unit's nameplate.
---	---	---

3.2.2.3 Tube in tube heat exchanger

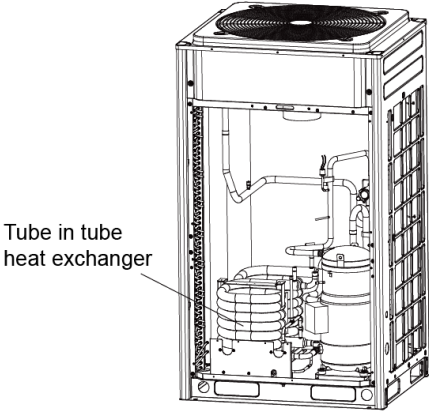
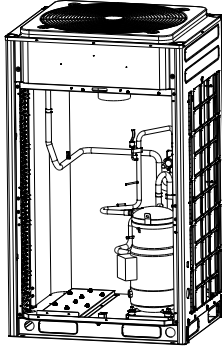
Removal/ Installation of tube in tube condenser		
Remarks: Check the refrigerant system and each circuit. After making sure that it is necessary to replace the tube in tube condenser, disconnect power and reclaim the refrigerant.		
Step	Figure	Operation Instructions
<p>1、 Reclaim the refrigerant and remove the fluorine connection pipe and waterway connection pipe of the tube in tube heat exchanger.</p>		<ul style="list-style-type: none"> • Disconnect power of the unit; • Reclaim the refrigerant; • Disconnect the fluorine connection pipe by using the soldering gun. Twist off the waterway connection pipe.
<p>2、 Take off the fixing nuts of tube in tube condenser and then remove the tube in tube condenser.</p>		<ul style="list-style-type: none"> • Take off the fixing nuts by using a spanner or other tools; • Remove the tube in tube condenser from the base plate.

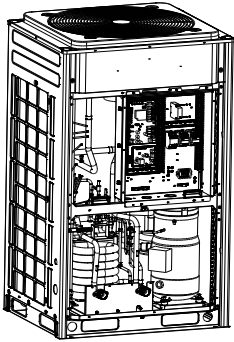
<p>3. Replace with a new tube in tube condenser and then secure the nuts. Weld the other pipelines.</p>		<ul style="list-style-type: none"> ● Install the new tube in tube condenser on the base plate; ● Use a spanner to tighten up the fixing nuts of tube in tube condenser; ● Weld the fluorine connection pipe and tighten the waterway connection pipe.
<p>4. Reclaim system pressure, vacuumize and recharge refrigerant.</p>	<p>—</p>	<ul style="list-style-type: none"> ● Detect system leakage; ● Make sure the vacuum degree reaches -1.0bar; ● Type and amount of refrigerant should accord with requirements on unit's nameplate.

3.2.2.4 Electronic expansion valve

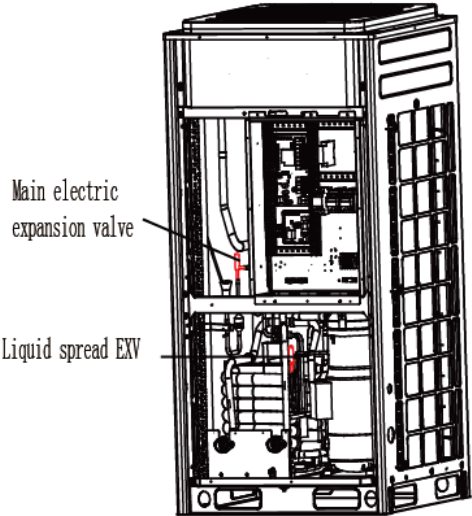
<p>Removal/ Installation of electronic expansion valve</p>		
<p>Remarks: Check the refrigerant system and each circuit. After making sure that it is necessary to replace electronic expansion valve, disconnect power and reclaim the refrigerant.</p>		
<p>Step</p>	<p>Figure</p>	<p>Operation Instructions</p>
<p>1. Detach the front panel and reclaim the refrigerant.</p>		<ul style="list-style-type: none"> ● Disconnect power of the unit; ● Retrieve the refrigerant.

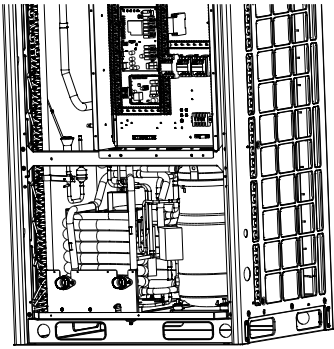
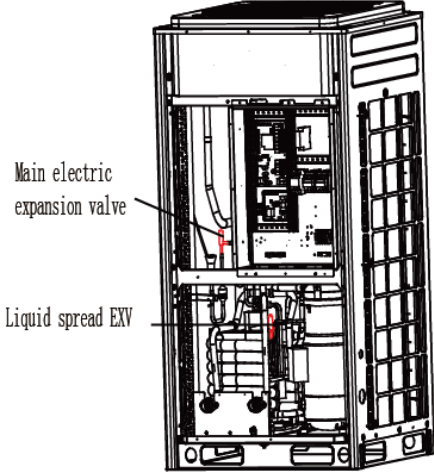
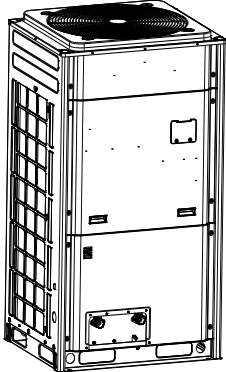
<p>2. Remove the electronic expansion valve that needs to be replaced.</p>		<ul style="list-style-type: none"> ● In order to protect the EXV, wrap it with wet cloth during welding; ● Remove the EXV by using the soldering gun.
<p>3. Replace with a new electronic expansion valve.</p>		<ul style="list-style-type: none"> ● Replace with a new EXV and that is of the same model; ● Wrap the EXV with wet cloth and mount it on. Connect the connection pipe; ● Weld it with soldering gun; ● Note: Add nitrogen into the pipe when welding.
<p>4. Retain system pressure, vacuumize and recharge refrigerant in. After confirming it's OK, install the front panel.</p>		<ul style="list-style-type: none"> ● Detect system leakage; ● Make sure the vacuum degree reaches -1.0bar; ● Type and amount of refrigerant should accord with requirements on unit's nameplate.

3.2.2.5 4-way valve

<p>Removal/ Installation of 4-way valve</p>		
<p>Remarks: Before replacing, cut off the power and reclaim refrigerant.</p>		
<p>Step</p>	<p>Figure</p>	<p>Operation Instructions</p>

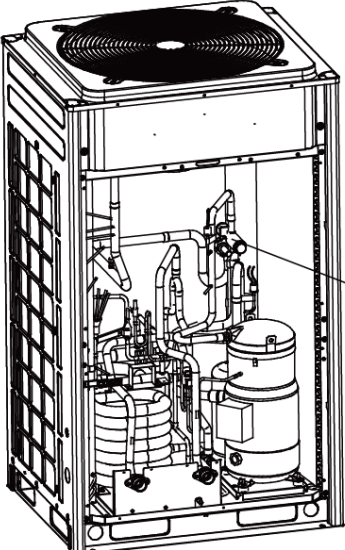
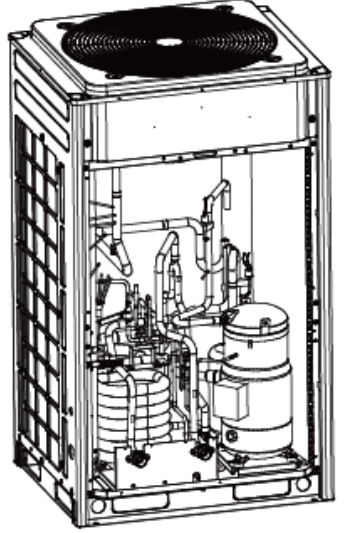
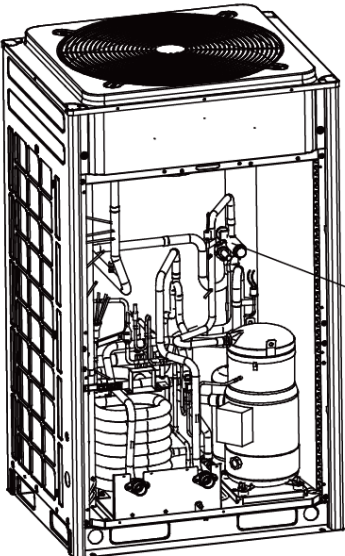
<p>1、 Remove the front panel and electric box according to the removal and installation instructions of compressor.</p>	 <p>4-way valve</p>	<ul style="list-style-type: none"> ● Reclaim the refrigerant; ● Before removing the 4-way valve, please remember the installed direction of the valve; ● Remove the coil.
<p>2、 Take away the 4-way valve assembly by welding and replace with a new 4-way valve. Weld the assembly according to the original angle.</p>	 <p>4-way valve</p>	<ul style="list-style-type: none"> ● In order to guarantee the integrity of 4-way valve and for future disassembly analysis, wrap the 4-way valve with wet cloth before welding; ● Remove the 4-way valve assembly by welding and remember the angle of pipes. After replacement of the valve, weld again.
<p>3、 Clean the system accordingly. Replace the 4-way valve with a same model. Pipe connection should also be consistent with the original connection of 4-way valve.</p>	 <p>4-way valve</p>	<ul style="list-style-type: none"> ● In principle, model of the new valve should be the same as the replaced one. In special cases where same model cannot be guaranteed, please ask professional technicians for confirmation; ● Wrap the 4-way valve with wet cloth; ● Use soldering gun to weld the pipes; ● Remember to charge nitrogen when welding.

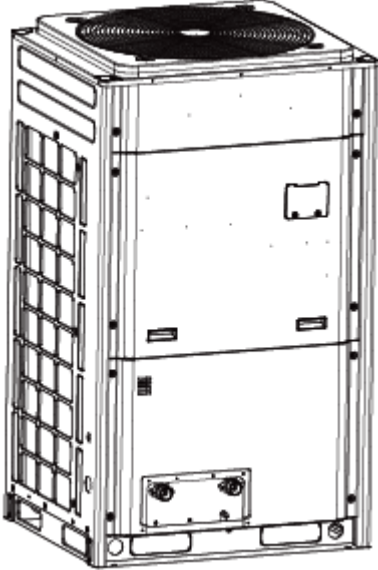
<p>4. Retain system pressure, vacuumize and recharge refrigerant. After confirming it's OK, install the middle beam, electric box and the front panel.</p>		<ul style="list-style-type: none"> • Detect system leakage; • Make sure the vacuum degree reaches -1.0bar; • Type and amount of refrigerant should accord with requirements on unit's nameplate.
--	---	---

3.2.3 Removal/Installation of GRS-Cm53/NaA-M、GRS-Cm53/NaA1-M main unit

3.2.3.1 Compressor

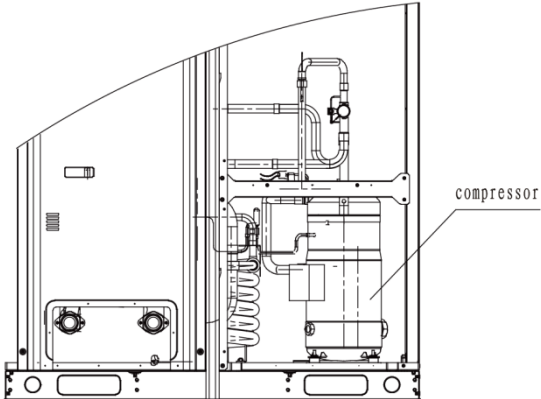
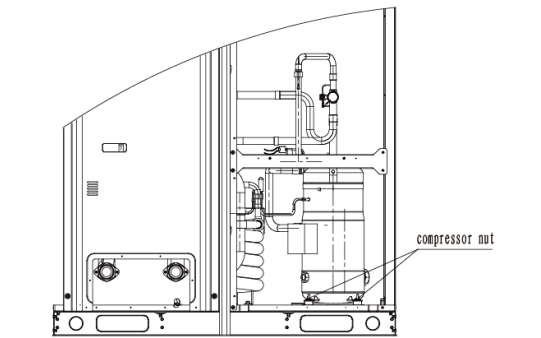
<p>Removal/ Installation of the compressor</p>		
<p>Remarks: Before removing the compressor, make sure there is no refrigerant in unit's pipeline system and power supply is cut off.</p>		
Step	Figure	Operation Instructions
<p>1、 Remove the right front panel (right side), compressor power cable and the electric heating band.</p>		<ul style="list-style-type: none"> • Use a screwdriver to detach the front panel (right side); • Use a screwdriver to loosen the fixing screws of power cord; • Then remove the compressor power cord and the electric heating band; • Reclaim the refrigerant.
<p>2、 Loosen the nuts fixing the compressor footing.</p>		<ul style="list-style-type: none"> • Use a screw wrench or other tools to twist off the fixing nuts of compressor.

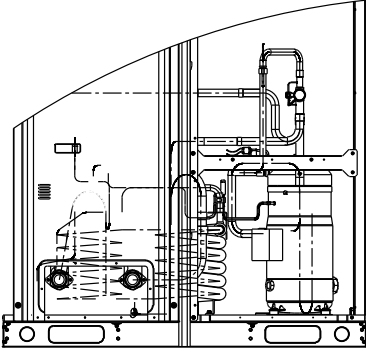
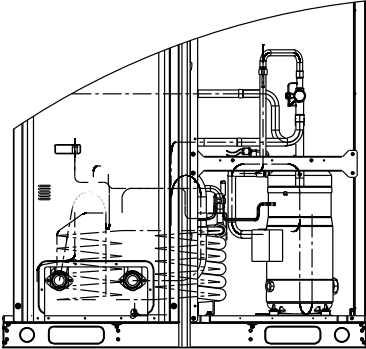
<p>3、Disconnect compressor from its connection pipes.</p>		<ul style="list-style-type: none"> ● When using a soldering gun, weld the pipes quickly to prevent pipeline from overburning; ● In order to guarantee the integrity of compressor and for future disassembly analysis, do not damage the compressor.
<p>4、Remove the compressor from the base plate and locate a new compressor onto the baseplate.</p>		<ul style="list-style-type: none"> ● When removing the compressor, be careful not to damage compressor's rubber grommet; ● The replaced compressor should be well sealed to prevent water from getting in; ● Place the newly replaced compressor onto the rubber grommets. Wear steel bushing on the center of the grommet; ● Tighten up the nuts to the position of steel bushing.
<p>5、Connect the suction port and discharge port of compressor to the system pipeline. Connect power cord and check whether the compressor can run normally.</p>		<ul style="list-style-type: none"> ● Connect the suction and discharge pipeline to the compressor by welding. Fill nitrogen during the welding; ● After welding, it is required to fill high pressure nitrogen to conduct leak test; ● Power on the unit and energize the AC contactor of the compressor manually to turn compressor on for 2~3 sec; ● If compressor is reversed, ear-piercing noise will occur.
<p>6、Retain system pressure, vacuumize and recharge refrigerant.</p>	<p>—</p>	<ul style="list-style-type: none"> ● Detect system leakage; ● Make sure the vacuum degree reaches -1.0bar; ● Type and amount of refrigerant should accord with requirements on unit's nameplate.

3.2.3.2 Gas-liquid separator

<p>Removal/ Installation of gas-liquid separator and liquid storage tank</p>
<p>Remarks: Reclaim refrigerant properly. Prepare related devices and tools. Make sure power is off.</p>

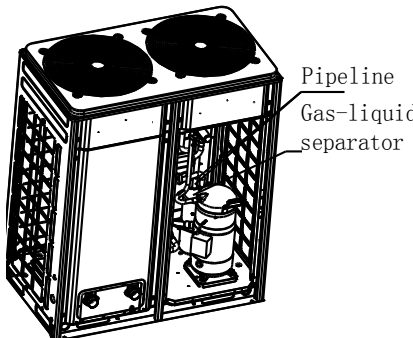
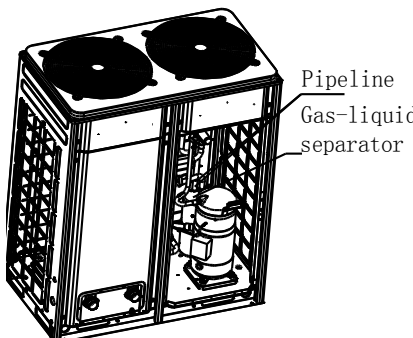
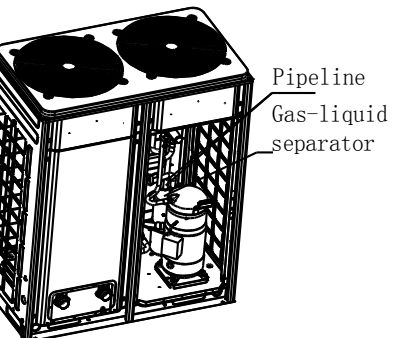
Step	Figure	Operation Instructions
<p>1、 Reclaim the refrigerant and then remove the gas-liquid separator. Take off the nuts and bolts on the base plate.</p>		<ul style="list-style-type: none"> ● Reclaim the refrigerant; ● Disassemble the connection pipes by welding; ● Use spanner or other tools to take off the fixing nuts and bolts. Remove the gas-liquid separator.
<p>2、 Clean the system accordingly. Replace with a same model gas-liquid separator.</p>		<ul style="list-style-type: none"> ● Replace with a same model gas-liquid separator. Secure it with nuts and bolts; ● Then connect the pipes with gas-liquid separator.
<p>3、 Assemble and weld the connection pipes of gas-liquid separator. Add nitrogen during welding for protection.</p>		<ul style="list-style-type: none"> ● Use soldering gun to weld the pipes; ● Note: Add nitrogen when welding.
<p>4、 Retain system pressure, vacuumize and recharge refrigerant.</p>		<ul style="list-style-type: none"> ● Detect system leakage; ● Make sure the vacuum degree reaches -1.0bar; ● Type and amount of refrigerant should accord with requirements on unit's nameplate.

3.2.3.3 Tube in tube condenser

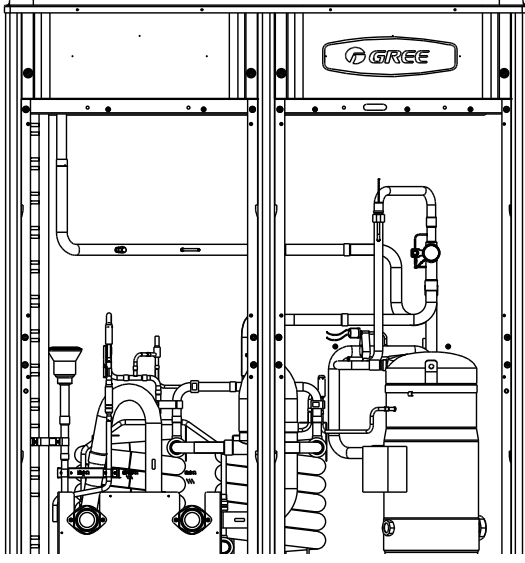
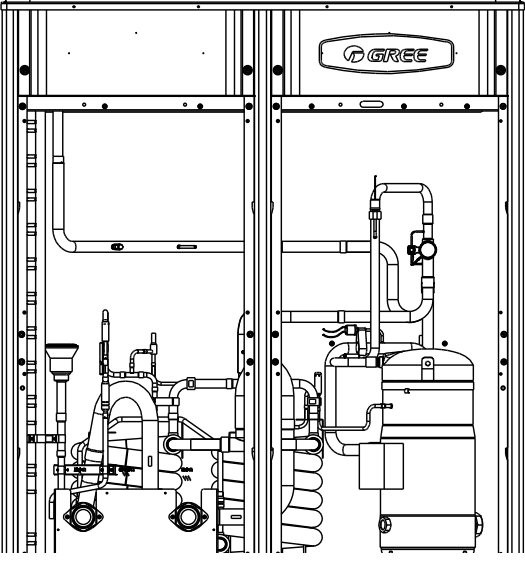
Removal/ Installation of tube in tube condenser		
Remarks: Check the refrigerant system and each circuit. After making sure that it is necessary to replace the tube in tube condenser, disconnect power and reclaim the refrigerant.		
Step	Figure	Operation Instructions
1、 Reclaim the refrigerant and remove the fluorine connection pipe and waterway connection pipe of the tube in tube heat exchanger.		<ul style="list-style-type: none"> ● Disconnect power of the unit; ● Retrieve the refrigerant; ● Disconnect the fluorine connection pipe by using the soldering gun. Twist off the waterway connection pipe.
2、 Take off the fixing nuts of tube in tube condenser and then remove the tube in tube condenser.		<ul style="list-style-type: none"> ● Take off the fixing nuts by using a spanner or other tools; ● Remove the tube in tube condenser from the base plate.

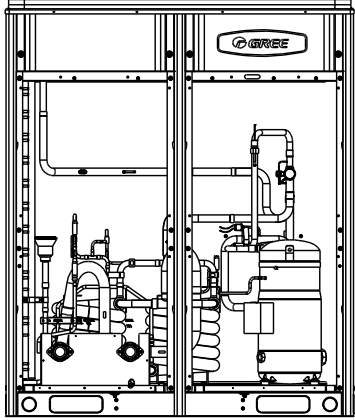
<p>3. Replace with a new tube in tube condenser and then secure the nuts.</p>		<ul style="list-style-type: none"> ● Install the new tube in tube condenser on the base plate; ● Use a spanner to tighten up the fixing nuts of tube in tube condenser; ● Weld the fluorine connection pipe and tighten the waterway connection pipe.
<p>4. Retain system pressure, vacuumize and recharge refrigerant.</p>	<p>—</p>	<ul style="list-style-type: none"> ● Detect system leakage; ● Make sure the vacuum degree reaches -1.0bar; ● Type and amount of refrigerant should accord with requirements on unit's nameplate.

3.2.3.4 Electronic expansion valve

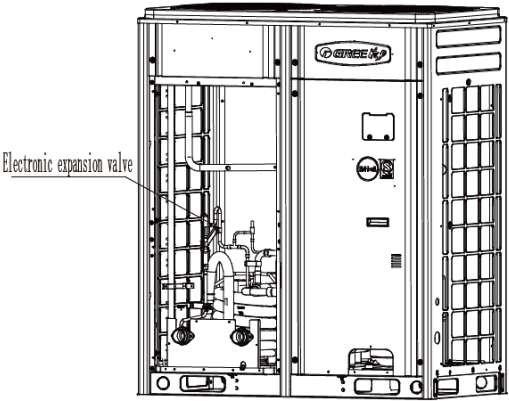
<p>Removal/ Installation of electronic expansion valve</p>		
<p>Remarks: Check the refrigerant system and each circuit. After making sure that it is necessary to replace electronic expansion valve, disconnect power and reclaim the refrigerant.</p>		
Step	Figure	Operation Instructions
<p>1 Reclaim the refrigerant.</p>		<ul style="list-style-type: none"> ● Disconnect power of the unit; ● Reclaim the refrigerant.

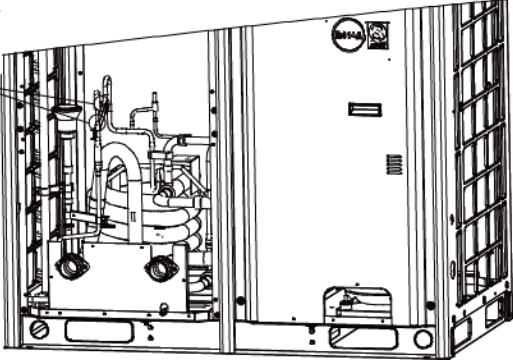
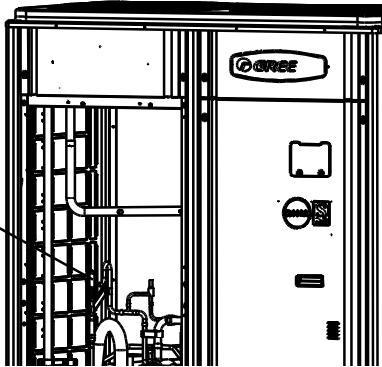
<p>2 、 Remove the electronic expansion valve.</p>	<p>Welding point</p> 	<ul style="list-style-type: none"> ● In order to protect the EXV, wrap it with wet cloth during welding; ● Remove the EXV by using the soldering gun.
<p>3 、 Replace with a new electronic expansion valve.</p>	<p>Electronic expansion valve</p> 	<ul style="list-style-type: none"> ● Replace with a new EXV that is of the same model; ● Wrap the EXV with wet cloth and mount it on. Connect the connection pipe; ● Weld it with soldering gun; ● Note: Add nitrogen into the pipe when welding.
<p>4、Retain system pressure, vacuumize and recharge refrigerant.</p>	<p>—</p>	<ul style="list-style-type: none"> ● Detect system leakage; ● Make sure the vacuum degree reaches -1.0bar; ● Type and amount of refrigerant should accord with requirements on unit's nameplate.

3.2.3.5 4-way valve

<p>Removal/ Installation of 4-way valve</p>		
<p>Remarks: Before replacing, cut off the power and reclaim refrigerant.</p>		
<p>Step</p>	<p>Figure</p>	<p>Operation Instructions</p>

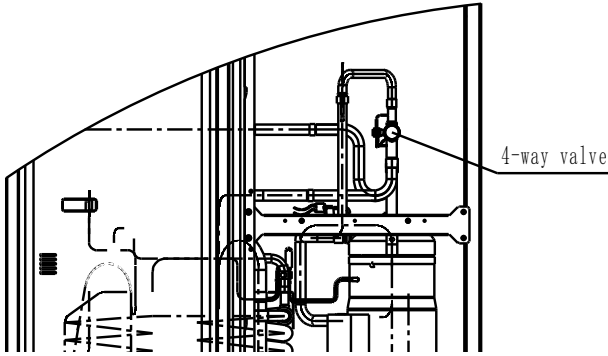
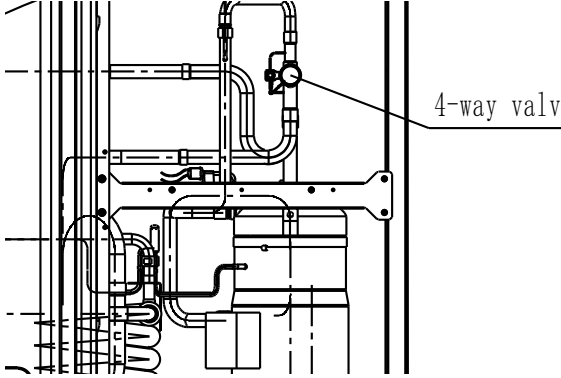
<p>1、Reclaim the refrigerant. Before removing the valve, record its direction. Even for a dual-system, do not refer to the other system for valve direction.</p>		<ul style="list-style-type: none"> ● Reclaim the refrigerant; ● Before removing the 4-way valve, please remember the installed direction of the valve; ● Remove the coil; ● In order to guarantee the integrity of 4-way valve and for future disassembly analysis, wrap the 4-way valve with wet cloth before welding; ● Remove the 4-way valve by welding.
<p>2、Clean the system accordingly. Replace the 4-way valve with a same model. Pipe connection should also be consistent with the original connection of 4-way valve.</p>		<ul style="list-style-type: none"> ● In principle, model of the new valve should be the same as the replaced one. In special cases where same model cannot be guaranteed, please ask professional technicians for confirmation; ● Wrap the 4-way valve with wet cloth; ● Connect the valve with the 4 pipes according to the original direction of valve coil; ● Weld the pipes with soldering gun; ● Remember to charge nitrogen when welding.
<p>3、Retain system pressure, vacuumize and recharge refrigerant.</p>	<p>—</p>	<ul style="list-style-type: none"> ● Detect system leakage; ● Make sure the vacuum degree reaches -1.0bar; ● Type and amount of refrigerant should accord with requirements on unit's nameplate.

4. Unit Explosion View and Parts List

4.1 GRS-Cm28/NaA-M

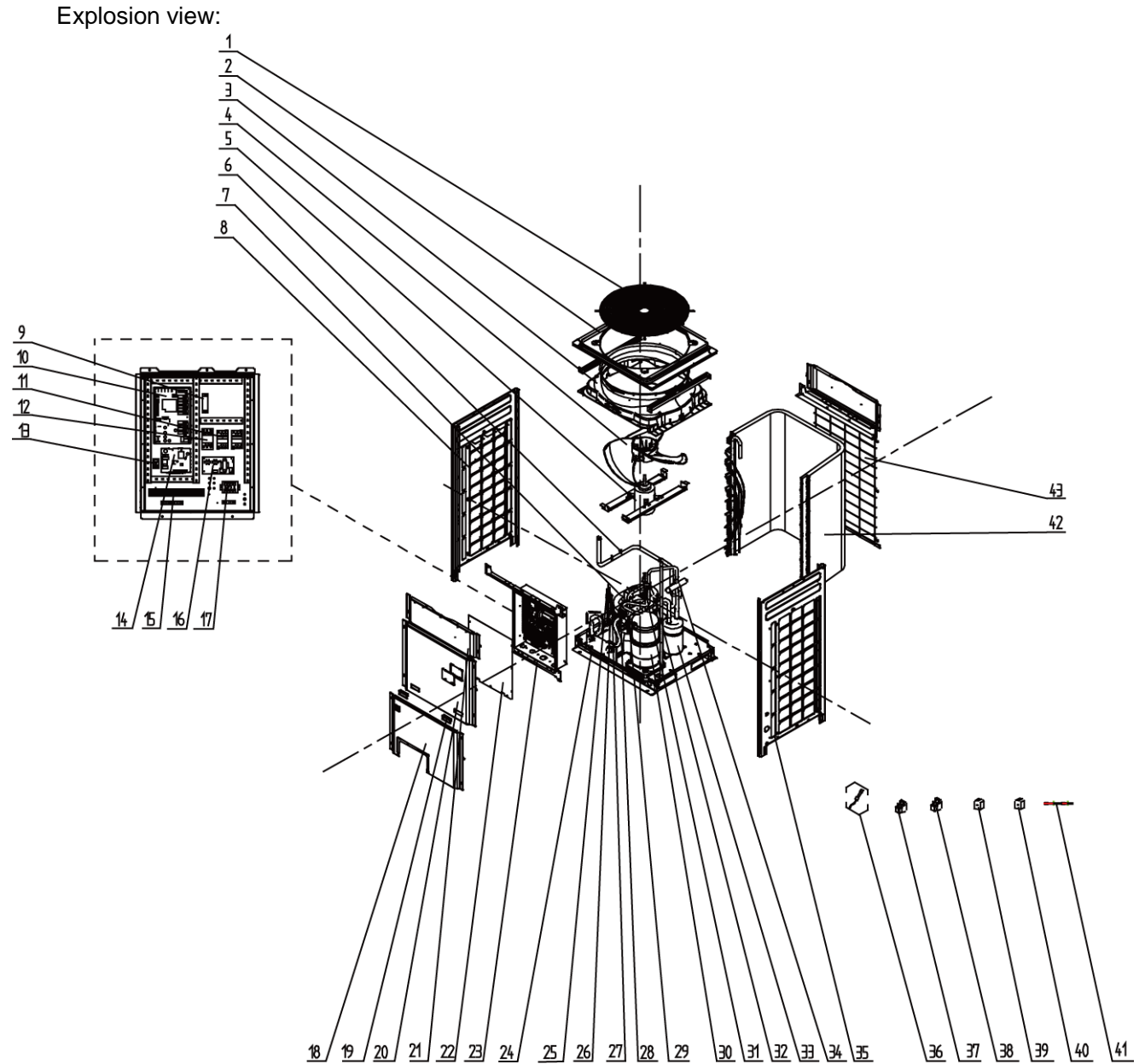

Chapter IV Maintenance (4. Unit Explosion View and Parts List)

Parts List of GRS-Cm28/NaA-M for ER01000150

No.	Item	Code	Quantity
1	Rear Grill	0157410501P	1
2	Coping	01264100030P01	1
3	Diversion Circle	1047410001	1
4	Axial Flow Fan Sub-Assy	10338702	1
5	Fan Motor	15703202	1
6	Nozzle for Adding Freon	06120016	2
7	Condenser Assy	01122800065	1
8	Right Side Plate	01314713P01	1
9	Phase Reverse Protector	32214101	1
10	Main Board	30220000026	1
11	AC Contactor	44010232	2
12	AC Contactor	44010213	1
13	Terminal Board	42011103	1
14	Main Board	30220000022	1
15	Terminal Board	42010249	1
16	Over Current Protector	46020103	1
17	Terminal Board	42011043	1
18	Lower panel	01542800026P	1
19	Handle	2690410001601	2
20	Front Panel	01544620P01	1
21	Top Cover	01264231P01	2
22	Electric Box Cover	01422800025P	1
23	Electric Box Assy	01392800163	1
24	Chassis Sub-assy	01282800036P	1
25	Strainer	0721004501	1
26	Strainer	07415210	1
27	Electronic Expansion Valve	07334390	1
28	Electromagnetic Valve	43000072	1
29	Electronic Expansion Valve	43042800008	1
30	Compressor	00202800015	1
31	Pressure Protect Switch	4602001594	1
32	Pressure Protect Switch	4602001578	1
33	Gas-liquid Separator	07424144	1
34	4-way Valve	43000339	1
35	Left Side Plate	01314712P01	1
36	Sensor Sub-assy	39008000076G	1
37	Electric Expand Valve Fitting	4304413205	1
38	Electric expand valve fitting	4304413202	1
39	Magnet Coil	430004017	1
40	Magnet Coil	4300008302	1
41	Electrical Heater	7651521120	2
42	Evaporator Assy	01022800019	1
43	Rear Grill	0157601301P	1

Above data is subject to change without notice, pls reference the SP in global service website.

4.2 GRS-Cm36/NaA-M

Explosion view:

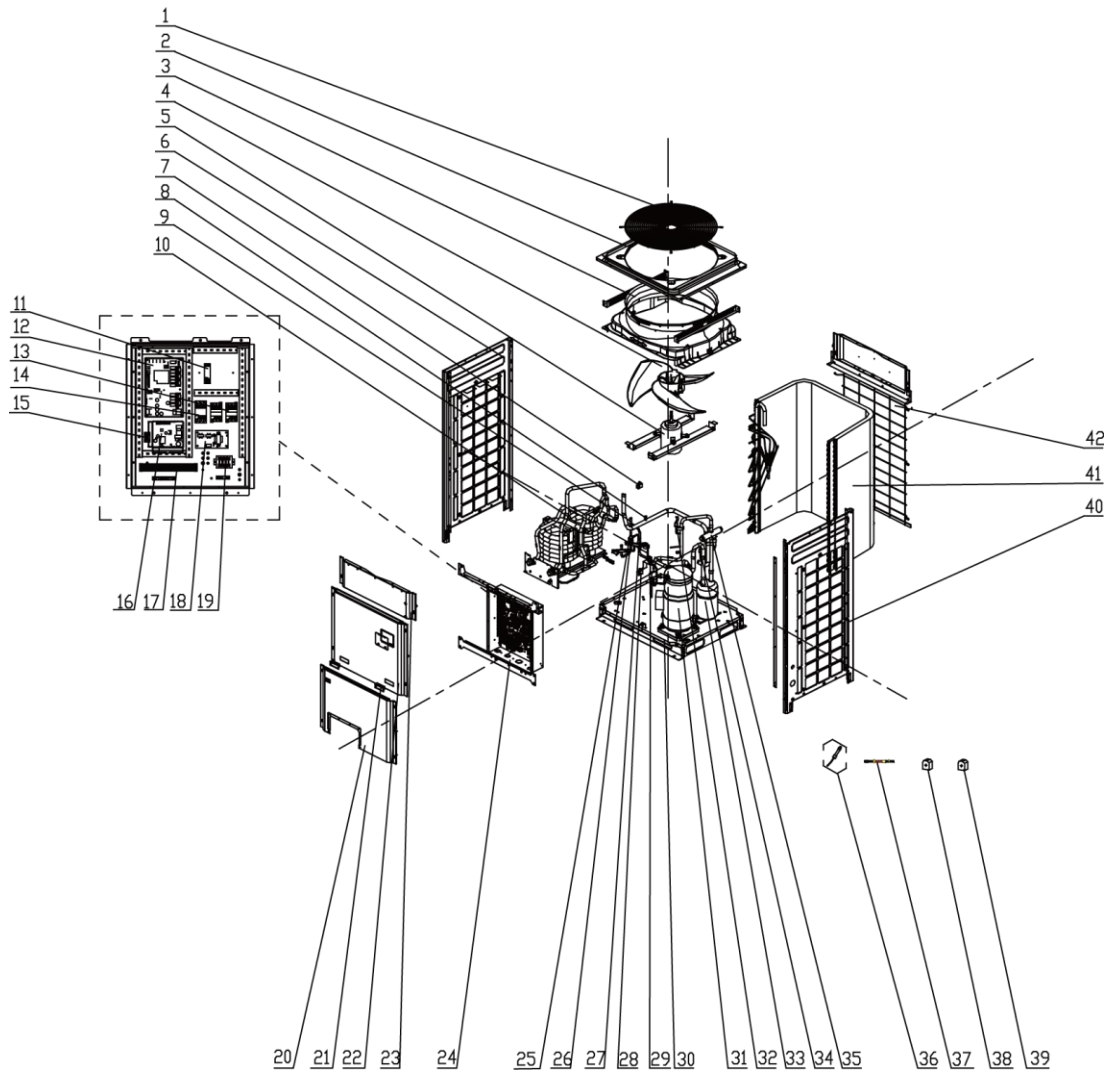

Parts list of GRS-Cm36/NaA-M for ER01000160:

No.	Item	Code	Quantity
1	Rear Grill	0157410501P	1
2	Coping	01264100030P01	1
3	Diversion Circle	1047410001	1
4	Axial Flow Fan Sub-Assy	10338702	1
5	Fan Motor	15703202	1
6	Right Side Plate	01314713P01	2
7	Electric Expand Valve Fitting	4304413205	1
8	Nozzle for Adding Freon	06120016	1
9	Electronic Expansion Valve	07334390	1
10	Condenser Assy	01122800047	1
11	Phase Reverse Protector	32214101	2
12	Main Board	30220000026	1
13	AC Contactor	44010232	1
14	AC Contactor	44010214	1
15	Terminal Board	42011103	1
16	Main Board	30220000022	1
17	Terminal Board	42010249	1
18	Over Current Protector	46020114	1
19	Terminal Board	42011043	2
20	Lower panel	01542800026P	1
21	Handle	2690410001601	2
22	Front Panel	01544620P01	1
23	Top Cover	01264231P01	1
24	Electric Box Assy	'01392800159	1
25	Strainer	07415210	1
26	Electromagnetic Valve	43000072	1
27	Strainer	0721004501	1
28	Electric expand valve fitting	4304413202	1
29	Electronic Expansion Valve	43042800007	1
30	Chassis Sub-assy	01192800023P	1
31	Compressor	00202800012	1
32	Pressure Protect Switch	4602001594	1
33	Gas-liquid Separator	07424144	1
34	Pressure Protect Switch	4602001578	1
35	4-way Valve	43000339	1
36	Sensor Sub-assy	39008000076G	1
37	Electrical Heater	7651521120	1
38	Magnet Coil	4300040044	1
39	Magnet Coil	4300008302	1
40	Left Side Plate	01314712P01	1
41	Evaporator Assy	01022800021	2
42	Rear Grill	0157601301P	1

Above data is subject to change without notice, pls reference the SP in global service website.

4.3 GRS-Cm53/NaA—M

Explosion view:

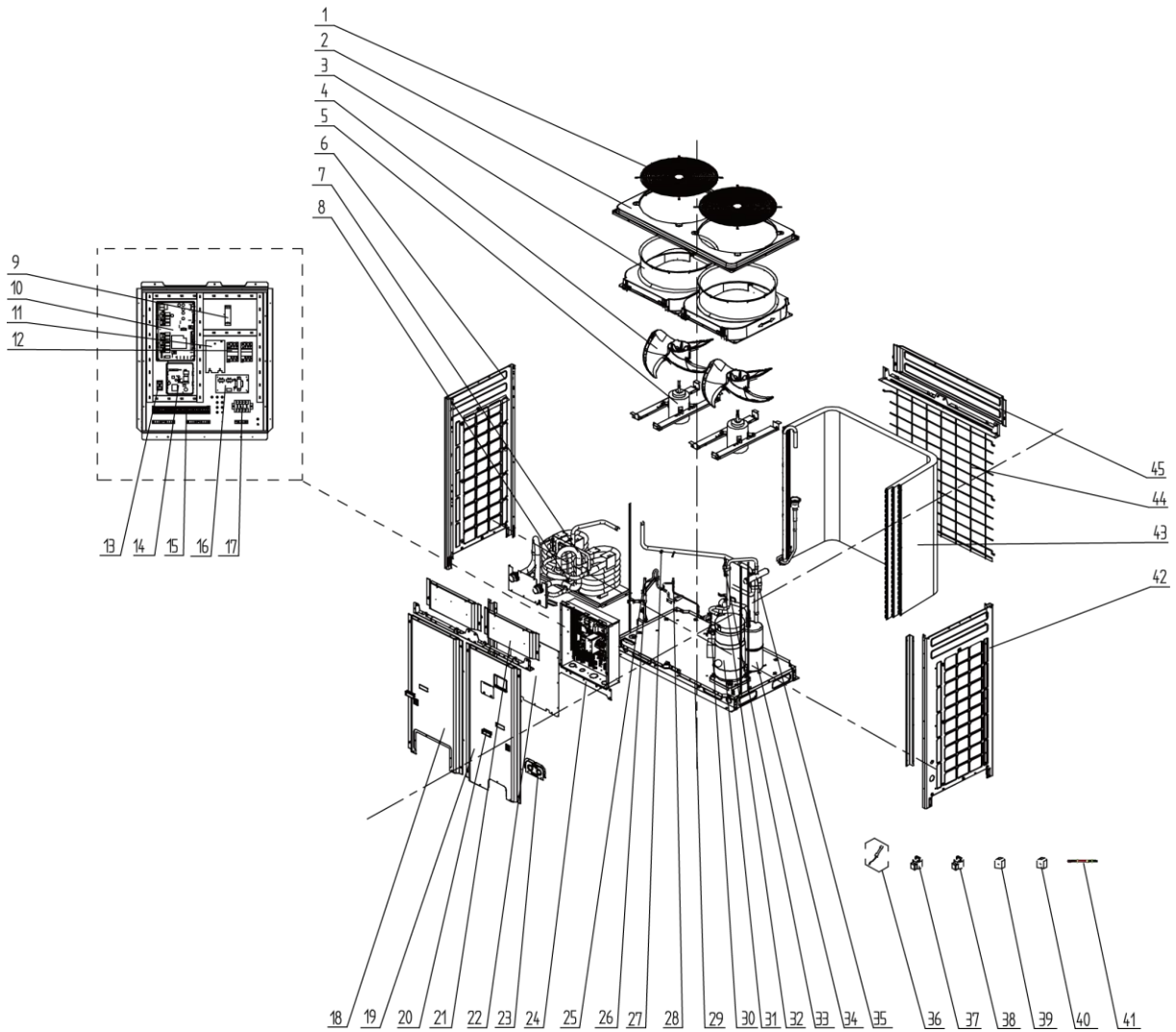

Parts list of GRS-Cm53/NaA-M for ER01000170:

No.	Item	Code	Quantity
1	Rear Grill	01574100002P	2
2	Coping	01264100006P01	1
3	Diversion Circle	1047410000201	2
4	Axial Flow Fan	10434100002	2
5	Fan Motor	15703202	2
6	Right Side Plate	01314713P01	1
7	Condenser Assy	01122800051	1
8	Strainer	'07212121	2
9	Phase Reverse Protector	32214101	1
10	Main Board	30220000026	1
11	AC Contactor	44010240	1
12	AC Contactor	44010232	2
13	Terminal Board	42011103	1
14	Main Board	30220000022	1
15	Terminal Board	42010249	1
16	Over Current Protector	46028000010	1
17	Terminal Board	42011051	1
18	Left Front Panel	01542800031P	1
19	Front Panel (right)	01544100005P01	1
20	Handle	2690410001601	2
21	Top Cover (front)	01264100004P01	2
22	Electric Box Cover	01422800032P	1
23	Sealing plate (Right Side)	01494869P01	1
24	Electric Box Assy	01392800162	1
25	Electronic Expansion Valve	07331139	1
26	Strainer	07212403	2
27	Nozzle for Adding Freon	06120016	2
28	Electromagnetic Valve	43000072	1
29	Chassis Sub-assy	01282800033P	1
30	Electronic Expansion Valve	43042800007	1
31	Compressor	00201100007	1
32	Pressure Protect Switch	4602001578	1
33	Pressure Protect Switch	4602001580	1
34	Gas-liquid Separator	07425215	1
35	4-way Valve	43000412	1
36	Sensor Sub-assy	39008000081G	1
37	Electric expand valve fitting	4304413206	1
38	Electric expand valve fitting	4304413202	1
39	Magnet Coil	4300008326	1
40	Magnet Coil	430004009	1
41	Electrical Heater	7651521120	2
42	Left Side Plate	01314712P01	1
43	Evaporator Assy	01022800020	1
44	Rear Grill	01574100001P	1
45	Upper Cover Plate (back)	01264100005P01	1

Above data is subject to change without notice, pls reference the SP in global service website.

4.4 GRS-Cm28/NaA1—M

Explosion view:

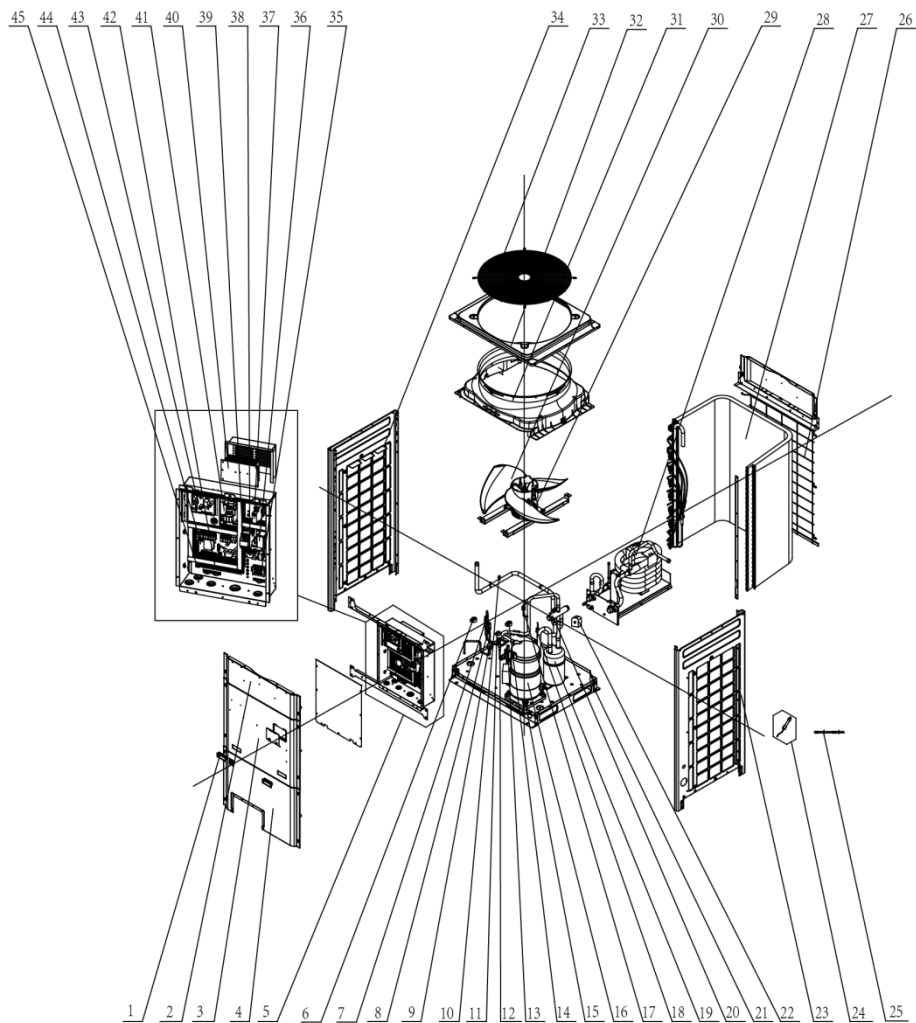

Parts list of GRS-Cm28/NaA1-M for ER01000180:

No.	Item	Code	Quantity
1	Handle	2690410001601	2
2	Top Cover	01264231P01	2
3	Front Panel	01544620P01	1
4	Lower Panel	01542800026P	1
5	Electric Box Assy	01392800217	1
6	Electric Expand Valve Fitting	4304413205	1
7	Strainer	0721004501	1
8	Electronic Expansion Valve	43042800070	
9	Strainer	07415210	1
10	Nozzle for Adding Freon	06120016	1
11	Magnet Coil	4300008302	1

Chapter IV Maintenance (4. Unit Explosion View and Parts List)

12	Electromagnetic Valve	43000072	1
13	Electronic Expansion Valve	43042800008	1
14	Electric Expand Valve Fitting	4304413202	1
15	Compressor Gasket	76815200004	4
16	Compressor and Fittings	00202800015	1
17	Pressure Protect Switch	4602001594	1
18	Pressure Protect Switch	4602001578	1
19	Gas-Liquid Separator	07424144	1
20	4-Way Valve	43041100041	1
21	Chassis Sub-Assy	01282800036P	1
22	Magnet Coil	430004017	1
23	Left Side Plate	01314712P01	1
24	Sensor Sub-assy	39008000076G	1
25	Electrical Heater(Compressor)	7651521120	2
26	Rear Grill	0157601301P	1
27	Evaporator Assy	01022800019	1
28	Condenser Assy	01122800065	1
29	Fan Motor	15704124	1
30	Axial Flow Fan Sub-Assy	10338702	1
31	Diversion Circle	1047410001	1
32	Coping	01264100030P01	1
33	Rear Grill	0157410501P	1
34	Right Side Plate	01314713P01	1
35	Terminal Board	42011043	1
36	Reactor	43130186	1
37	Phase Reverse Protector	32214101	1
38	Over Current Protector	46020103	1
39	AC Contactor	44010213	1
40	Radiator	49018000013	1
41	Main Board	30223000037	1
42	Terminal Board	42010249	1
43	Main Board	30220000022	1
44	Main Board	30220000040	1
45	Terminal Board	42011103	1

Above data is subject to change without notice, pls reference the SP in global service website.

4.5 GRS-Cm36/NaA1—M

Explosion view:

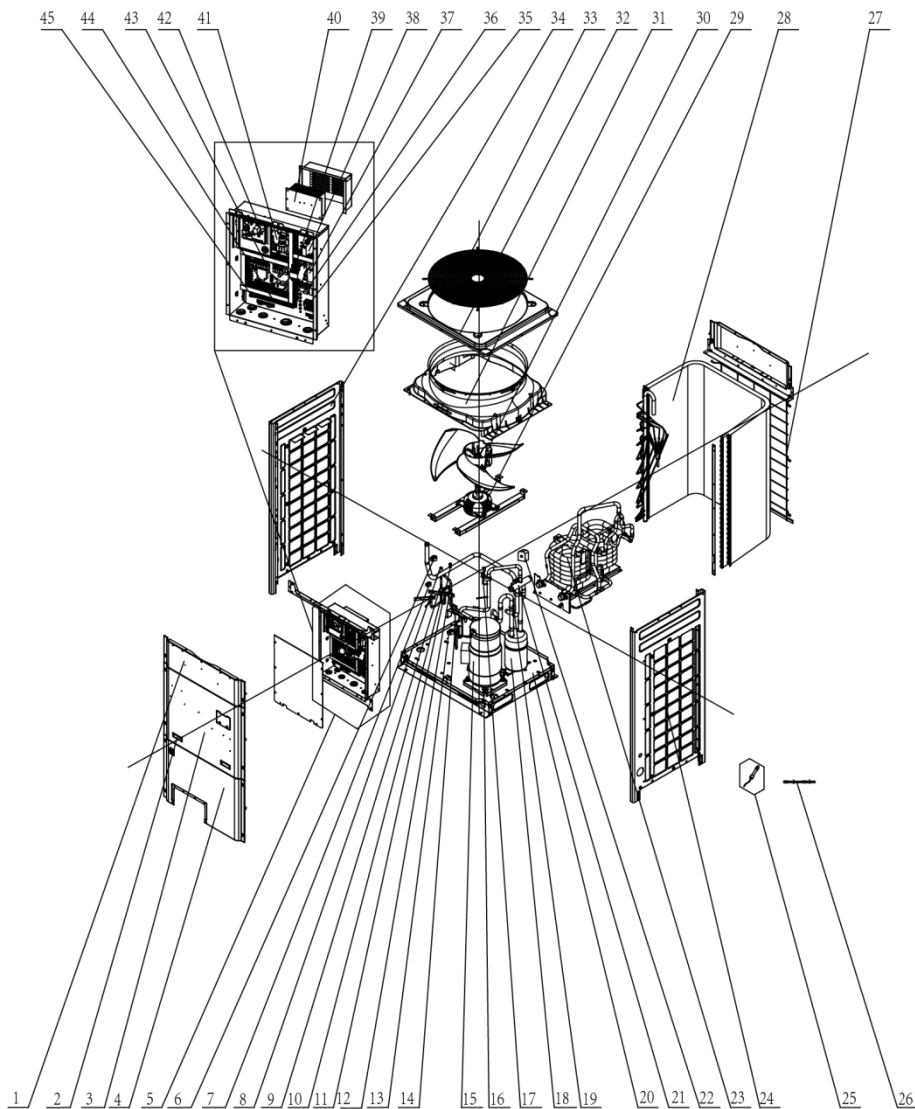

Parts list of GRS-Cm36/NaA1-M for ER01000190:

No.	Item	Code	Quantity
1	Top Cover	01264231P01	2
2	Handle	2690410001601	2
3	Front Panel	01544620P01	1
4	Lower Panel	01542800026P	1
5	Electric Box Assy	01392800216	1
6	Electric Expand Valve Fitting	4304413205	1
7	Magnet Coil	4300008302	1
8	Electronic Expansion Valve	43042800070	1
9	Electromagnetic Valve	43000072	1
10	Strainer	07415210	1
11	Nozzle for Adding Freon	06120016	1
12	Strainer	0721004501	1

Chapter IV Maintenance (4. Unit Explosion View and Parts List)

13	Electric Expand Valve Fitting	4304413202	1
14	Electronic Expansion Valve	43042800007	1
15	Compressor and Fittings	00202800012	1
16	Compressor Gasket	76815200004	4
17	Pressure Protect Switch	4602001594	1
18	Gas-liquid Separator	07424144	1
19	Pressure Protect Switch	4602001578	1
20	Chassis Sub-Assy	01192800023P	1
21	4-Way Valve	43041100041	1
22	Magnet Coil	4300040044	1
23	Condenser Assy	01122800047	1
24	Left Side Plate	01314712P01	1
25	Sensor Sub-Assy	39008000076G	1
26	Electrical Heater	7651521120	2
27	Rear Grill	0157601301P	1
28	Evaporator Assy	01022800021	1
29	Fan Motor	15704124	1
30	Axial Flow Fan Sub-Assy	10338702	1
31	Diversion Circle	1047410001	1
32	Coping	01264100030P01	1
33	Rear Grill	0157410501P	1
34	Right Side Plate	01314713P01	1
35	Terminal Board	42011043	1
36	Over Current Protector	46020114	1
37	Reactor	43130186	1
38	Phase Reverse Protector	32214101	1
39	AC Contactor	44010214	1
40	Radiator	49018000013	1
41	Main Board	30223000037	1
42	Main Board	30220000022	1
43	Main Board	30220000040	1
44	Terminal Board	42010249	1
45	Terminal Board	42011103	1

Above data is subject to change without notice, pls reference the SP in global service website.

4.6 GRS-Cm53/NaA1—M

Explosion view:

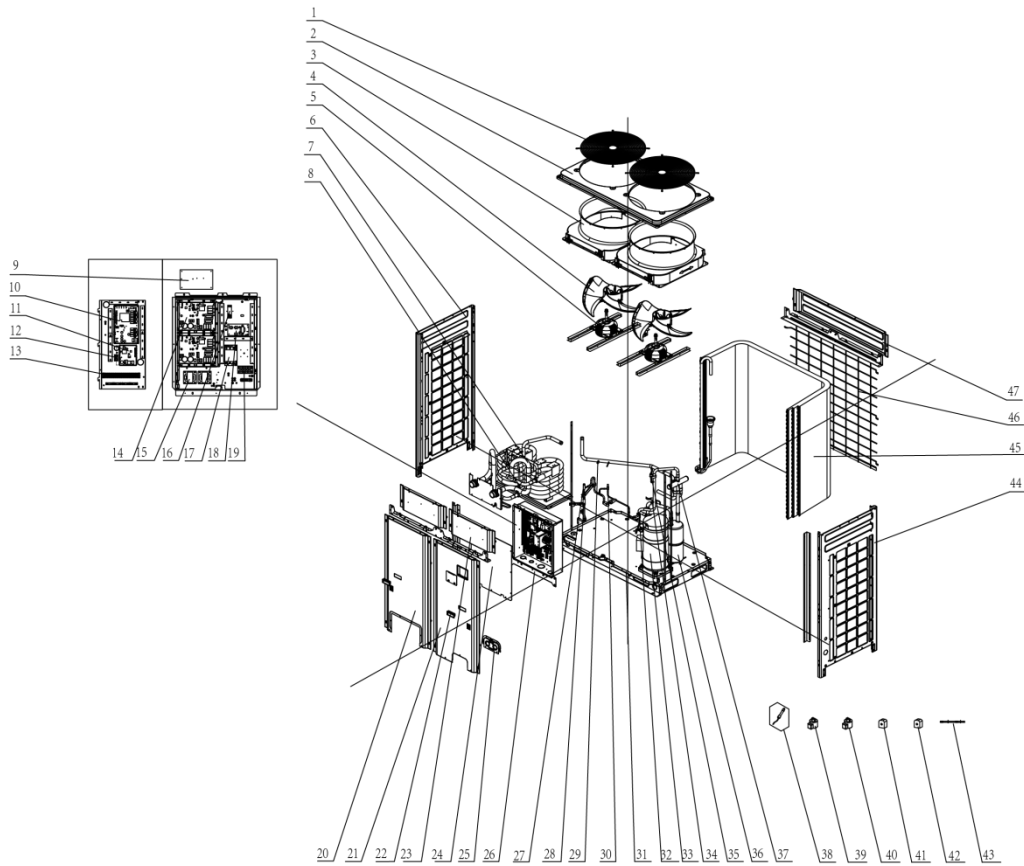

Parts list of GRS-Cm53/NaA1-M for ER01000200:

No	Item	Code	Quantity
1	Rear Grill	01574100002P	2
2	Coping	01264100006P01	1
3	Diversion Circle	1047410000201	2
4	Axial Flow Fan	10434100002	2
5	Fan Motor	15704124	2
6	Right Side Plate	01314713P01	1
7	Condenser Assy	01122800051	1
8	Strainer	07212121	2
9	Radiator	49018000013	2
10	Main Board	30220000040	1
11	Main Board	30220000022	1
12	Terminal Board	42011103	1
13	Terminal Board	42010249	1
14	Main Board	30223000037	2

Chapter IV Maintenance (4. Unit Explosion View and Parts List)

15	Reactor	43130186	2
16	Phase Reverse Protector	32214101	1
17	Over Current Protector	4602800010	1
18	AC Contactor	44010240	1
19	Terminal Board	42011051	1
20	Left Front Panel	01542800031P	1
21	Front Panel (right)	01544100005P01	1
22	Handle	2690410001601	2
23	Top Cover (front)	01264100004P01	2
24	Electric Box Cover	01422800032P	1
25	Sealing plate (Right Side)	01494869P01	1
26	Electric Box Assy	01392800212	1
27	Electronic Expansion Valve	43042800067	1
28	Strainer	07212403	1
29	Nozzle for Adding Freon	06120016	2
30	Electromagnetic Valve	43000072	1
31	Chassis Sub-assy	01282800033P	1
32	Electronic Expansion Valve	43042800007	1
33	Compressor	00201100007	1
34	Pressure Protect Switch	4602001578	1
35	Pressure Protect Switch	4602001580	1
36	Gas-liquid Separator	07425215	1
37	4-way Valve	43000412	1
38	Sensor Sub-assy	39008000081G	1
39	Electric expand valve fitting	4304413206	1
40	Electric expand valve fitting	4304413202	1
41	Magnet Coil	4300008326	1
42	Magnet Coil	430004009	1
43	Electrical Heater	7651521120	2
44	Left Side Plate	01314712P01	1
45	Evaporator Assy	01022800030	1
46	Rear Grill	01574100001P	1
47	Upper Cover Plate (back)	01264100005P01	1

Above data is subject to change without notice, pls reference the SP in global service website.

Chapter V Unit Maintenance

1. Daily Operation and Maintenance

- (1) At the time of ex-factory time, all the safety protection devices have been set. Users cant adjust or eliminated it by themselves in order to avoid unit damage.
- (2) For the first operation of the unit or restart up the unit when the unit has been cut off power for a long time (24h above), connect the supply power of the unit in advance to preheat the unit for 8 hours above for avoiding damage to the compressor.
- (3) Do not pile up sundries on the unit and its accessories. The surroundings of the unit should be kept dry, clean and well-ventilated. If theres too much dust on the fins of condenser, please eliminate them in time to prevent affecting performance of unit.
- (4) Clean the strainer inside the water system periodically to prevent protection or damage to the unit due to blockage of the water system. Meanwhile, frequently check whether the water supplement device inside the water system is normal.
- (5) If the ambient temperature in winter is below 0℃, prohibit cutting off the power. Otherwise, anti-freezing protection of the unit will be invalid.
- (6) When the unit wont be used for a long time, you should not only discharge the water inside the unit and pipeline system, but also remove the choke plug of water tank to discharge the water inside the water tank for preventing freezing of the unit.
- (7) Do not turn on or turn off the unit frequently. Do not close the regulator valve of water system with hand freely during operation.
- (8) Please check the working status of all parts of the unit. Check whether theres grease on the pipeline joints inside the unit and refrigerant-charging valve to make sure theres no refrigerant leakage.
- (9) If theres malfunction for the unit and the user cant solve it, please contact local appointed maintenance center in time.

2. Cleaning of System

2.1 Cleaning Fin-type Heat Exchanger

In consideration of better heat exchange effect, the air-cooled fin-type heat exchanger for the water heater is usually placed outdoors. After operating for a period of time, the fin is blocked up with dirt such as dust, affecting heat exchange effect of the fin-type heat exchange, reducing the heating effect and increasing power consumption. The fin-type heat exchanger needs to be cleaned if the unit has operated for 6 to 12 months. The cleaning cycle must be shortened when contamination of the environment is severe.

Cleaning method:

- (1) Cut off power supply of the heater.
- (2) Use high-pressure gas to wash the fin repeatedly to the direction reverse to air inlet of

the heat exchanger. Wash the fin by making the gas vertical to it, lest the fin would be turned over.

(3) You can also use high-pressure water. Control the water pressure well in the washing process, prevent the fin from being turned over, and protect electrical components. If the fin is contaminated with greasy substance, use water mixed with neutral detergent to wash it.

(4) You can also use a vacuum cleaner and a nylon brush to clean dust and stain from surface of the heat exchanger.

(5) Finally, the original color of the fin can be seen or water flowing along the fin is clean water. Then, the cleaning is finished.

2.2 Cleaning Water System

After use for a long term, the waterway system may suffer from scale formation. The waterway system should be cleaned; otherwise it may lead to poor heat exchange and unideal heating effect, or even blocking of the waterway system and damage to the unit. Therefore, you must regularly clean the waterway system. The recommended frequency is 6 to 12 months. The unit can be cleaned by using organic acid such as oxalic acid, acetic acid, and formic acid, but not strong acid containing chlorine, because the strong acid may erode the heat exchange copper pipe in the heat exchanger, thus leading to mixing of water and refrigerant. Clean the water system as follows:

- (1) Turn on circulating pump manually;
- (2) Add detergent to the water tank according to a fixed proportion;
- (3) After adding the detergent, continue circulation until scale is cleared; drain water with detergent from the water tank and the unit. Use the above cleaning function of direct heating mode and circulating cleaning function to clean out the detergent that may remain in the pipeline and unit, until the water quality reaches the requirement.



JF00302529

GREE ELECTRIC APPLIANCES, INC. OF ZHUHAI

Add: West Jinji Rd, Qianshan, Zhuhai, Guangdong, China, 519070

Tel: (+86-756) 8522218 Fax: (+86-756) 8669426

E-mail: gree@gree.com.cn www.gree.com

For continuous improvement in the products, Gree reserves the right to modify the product specification and appearance in this manual without notice and without incurring any obligations.